

18  
CE

WURLITZER®

# PRINCESS



OPERATING INSTRUCTIONS  
FIELD SERVICE MANUAL



**WARNING!** Although the beam emitted by the laser diodes is nearly invisible, it may cause severe damage to the human eye. Use an infrared indicator to check the laser beam.



**ATTENTION!**

The CD mechanism and many ICs are extremely susceptible to electrostatic discharges. The photo diodes and the laser diode are more sensitive to discharges than MOS ICs. Careless handling may immediately destroy components or can drastically reduce life expectancy of these components so that it will lead to failure after several weeks or even months of use.

Before you touch the player, discharge your hands and tools by touching a grounded metal part of the jukebox, such as the amplifier or the mechanism chassis. Make sure that you are connected via a wrist wrap with resistance to the same potential as the chassis of the jukebox. Keep parts and tools at the same potential.

If you remove the player in case of repair or for transport, short the harness with a short circuit plug.

When repairing, observe all valid safety rules. Do not change the original condition of the jukebox. Use original spare parts only.



This manual belongs to machines equipped with program versions 4.09 (or higher).

**Subject to alterations.**

<b>1</b>	<b>Unpacking - Installation</b> .....	<b>4</b>
1.1	Unlocking .....	4
1.2	Removal of shipping guards .....	4
1.3	Verification of power voltage .....	4
1.4	Wall mounting .....	5
1.5	Speaker connection .....	5
1.6	Power on .....	6
<b>2</b>	<b>Loading compact discs</b> .....	<b>7</b>
2.1	Position of CDs in the magazines .....	7
2.2	Remove magazines .....	7
2.3	CD handling precautions - CD and player cleaning .....	8
2.4	Inserting title cards .....	9
2.5	Programming number of CDs in the magazines .....	10
2.6	Adjustment of the page limitation .....	11
<b>3</b>	<b>Coin operation or free play?</b> .....	<b>12</b>
3.1	Coin operation .....	12
3.2	Free play .....	12
3.3	Test credit .....	13
<b>4</b>	<b>Track selections</b> .....	<b>14</b>
4.1	How to select a track .....	14
4.2	I do not like this track - the button CANCEL .....	15
4.3	Albumplay - playing a whole CD .....	16
<b>5</b>	<b>Automatic random select</b> .....	<b>17</b>
<b>6</b>	<b>Volume, sound and balance control</b> .....	<b>18</b>
6.1	Volume, sound and balance control - amplifier F91 .....	18
6.2	Volume, sound and balance control - amplifier K99 .....	20
<b>7</b>	<b>Coin and price settings</b> .....	<b>22</b>
7.1	Price settings .....	22
7.2	Examples .....	22
7.3	Free play programming .....	23
7.4	Color codes of coin input .....	23
7.5	Selecting, displaying and programming of top tunes .....	24
<b>8</b>	<b>Programming short view</b> .....	<b>26</b>
<b>9</b>	<b>Jukebox programming</b> .....	<b>27</b>
9.1	Calling service programs .....	27
9.2	Programming of time functions .....	28
9.3	Programming of the Playstimulator (random selections without coin insertion) .....	29
9.4	BackGround Music (BGM), level 3 .....	31
9.5	Happy hour pricing (additional bonus plays) .....	34
9.6	Number of tracks played successively on the same disc, level 2 button 3 .....	35
9.7	Disabling single tracks .....	35

9.8	Location or Identification number, level 1 button 8 .....	36
9.9	Album selection and memory reset by power off, level 1 button 9 .....	37
<b>10</b>	<b>Data retrieval .....</b>	<b>38</b>
10.1	Operator data .....	38
<b>11</b>	<b>Amplifier F91 .....</b>	<b>41</b>
11.1	Verification of power voltage .....	41
11.2	Position of fuses and plug connectors on the power amp board .....	42
11.3	The first power ON .....	43
11.4	Pre-settings for volume, bass, treble .....	43
11.5	Speaker connections .....	45
11.6	Connecting external speakers in operating mode 2-CHANNEL .....	47
11.7	BGM mode - volume attenuation .....	48
11.8	Automatic volume control (AVC) and clipping stage .....	48
11.9	Overdrive protection .....	48
11.10	Overload protection .....	49
11.11	Tape input .....	49
<b>12</b>	<b>Amplifier K99 .....</b>	<b>50</b>
12.1	Device description of the amplifier K99 .....	50
12.2	Technical data .....	50
12.3	Verification of power voltage .....	51
12.4	Position of fuses and plug connectors .....	52
12.5	The first power ON .....	53
12.6	Volume control .....	53
12.7	The infrared remote control .....	54
12.8	Treble and bass control .....	55
12.9	Automatic volume correction .....	55
12.10	Background Music - volume attenuation .....	55
12.11	External speaker connection .....	56
12.12	External amplifier connection .....	57
12.13	Disabling the internal mute circuit .....	58
12.14	Input selector .....	58
<b>13</b>	<b>70v output transformer (0043157) .....</b>	<b>59</b>
13.1	Hints of connectable speaker loads .....	59
13.2	Determination of the connectable speaker power .....	60
13.3	Hints for speaker connection .....	60
13.4	Connection of 70v systems .....	61
<b>14</b>	<b>Technician Statistics .....</b>	<b>62</b>
14.1	Service data, level 4 button 8 .....	62
<b>15</b>	<b>Function tests .....</b>	<b>65</b>
15.1	Digital display test / EPROM-version, level 1 button 4 .....	65
15.2	Mechanism single step tests .....	65
15.3	Light gate tests .....	68

---

15.4	CD-PRO function tests, level 5 .....	70
<b>16</b>	<b>Integrated test program of the CD-PRO player .....</b>	<b>72</b>
16.1	Access to the player functions without S&CC unit .....	72
16.2	Special test functions of the CD-PRO player .....	74
<b>17</b>	<b>Accessories .....</b>	<b>75</b>
17.1	Microfone kit (part no. 0006953).....	75
17.2	BGM-Connector .....	75
<b>18</b>	<b>Steps to solve mechanical problems .....</b>	<b>76</b>
18.1	Treating simple errors.....	76
18.2	Treating simple errors by hand .....	76
18.3	Set the mechanism to '0' position .....	76
<b>19</b>	<b>Declaration of Conformity .....</b>	<b>78</b>

# 1 Unpacking - Installation

## 1.1 Unlocking

The key is stored in the coin return cup in the RH bottom side of the door. The key WUA 1 unlocks the cabinet by turning the key clockwise. The lock is spring loaded, press slightly against the door, this allows to turn the key easily. The two other keys with 5 digit number codes unlock the cash box inside of the cabinet. In this box also the hand transmitter is located.

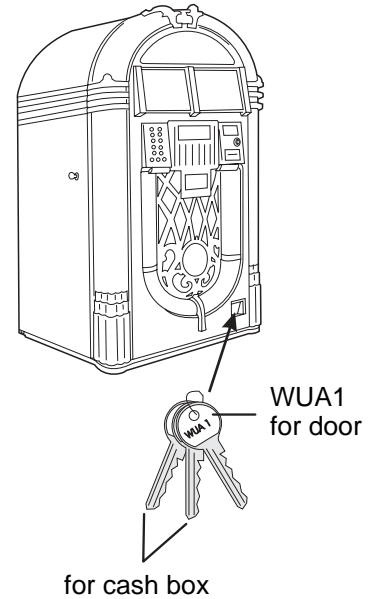

## 1.2 Removal of shipping guards

1. Remove elastic band from the magazine cabinet.
2. Open the magazine cabinet.
3. Push the latch bar of one magazine inwards and take it out.
4. Remove elastic band and release the wing screw up to limit stop.
5. Insert the magazine again and proceed the same way with the second magazine.
6. Finally remove the CD lens cover.



**NOTE:** Save the removed shipping guards. You may need them should you decide to move your machine to another location.

## 1.3 Verification of power voltage

Compare your power voltage with the voltage printed on the label inside of the door. If your voltage does not match the voltage of the label do not switch on the jukebox. Contact your dealer to set the voltage according to your mains.

In case of standard UL-versions (for USA) it is impossible to adjust another voltage.

At the other types you can check and modify the power setting on the power transformer of the amplifier. It is described in the according chapters 'amplifier F91' [see page 41](#) and 'amplifier K99' [see page 50](#).

For any service call please have ready your serial and version number.

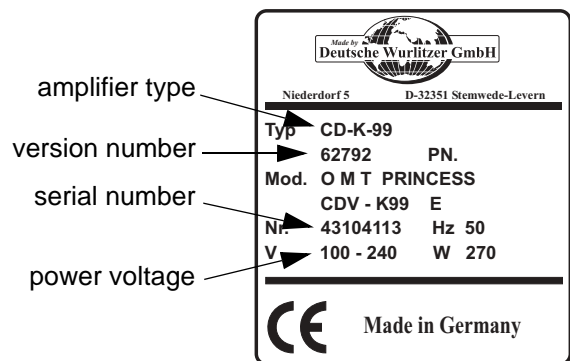

### 1.4 Wall mounting

Depending on the installed amplifier the weight of the jukebox is 78kg (amplifier K99) to 85kg (amplifier F91). Because of this take great pains when you mount it on a wall. Use the delivered mounting frame (part no. 0051361) and check the structural quality of the wall. Calculate a security factor of 2 (170kg) for home use and a factor of 4 (340kg) for public use when you select your dowels. Use all the dowel holes of the frame. Contact your architect and a dowel manufacturer to select suitable mounting devices. The manufacturer does not accept liability for damages caused of not proper mounted machines!

Fasten the jukebox with the locking bolt which you will find in the accessories.

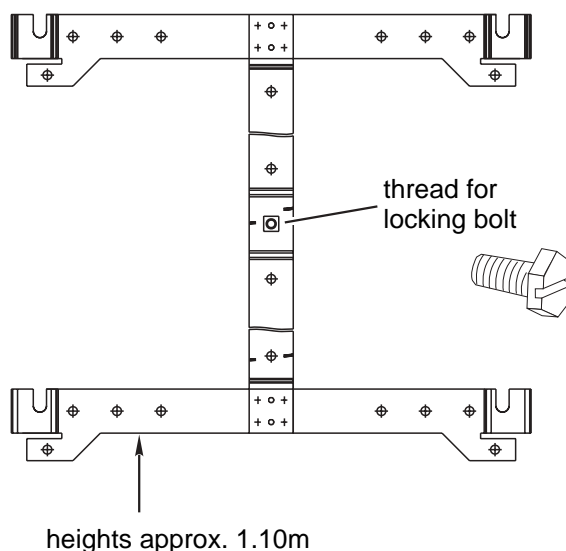

### 1.5 Speaker connection

To attain a good sound of the jukebox, take care when connecting the speakers. Connect the speakers to either the terminals inside the jukebox or to the terminals on the back side. Pay attention of the correct polarity. The red terminals belong to "+" the black ones to "-".

The jukebox can be delivered with two different amplifiers F91 or K99. You can distinguish both types by means of the product label inside the door or compare your amplifier with the pictures below here.

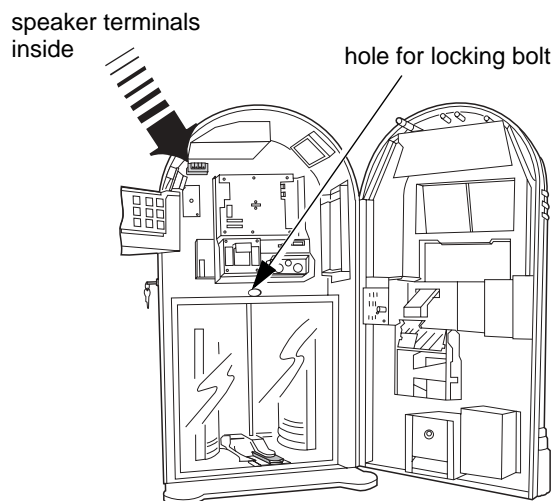

Both amplifiers may not be loaded with more than 4Ω per channel. Less Ohm means more load! The output of the amplifier K99 to a 4Ω load is 55 Watts rms power at 1 % distortion, to 8Ω it is about 28 Watts, to 12Ω it is about 18 Watts.

The output of the amplifier F91 to a 4Ω load is 170Watts rms power, to 8Ω it is about 85 Watts, to 12Ω it is about 57 Watts.

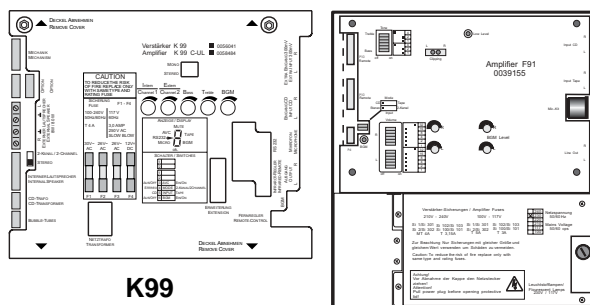

K99

F91

If the amplifier is operating in 2-Channel mode, the speakers at the external terminals are all loaded in parallel to the left hand channel. If you use 4Ω speakers you must disconnect one speaker from the terminals before you switch the jukebox to 2-channel mode.

The right channel (now switched to the sockets "R-Extern" and "L-Extern") now may be also loaded with a minimum of 4Ω.

Note that speaker groups like in hi-fi boxes may have, at certain frequencies, impedances much lower than their rating.

After having connected all speakers disconnect the monitor speaker inside the jukebox. It is for test purposes only.

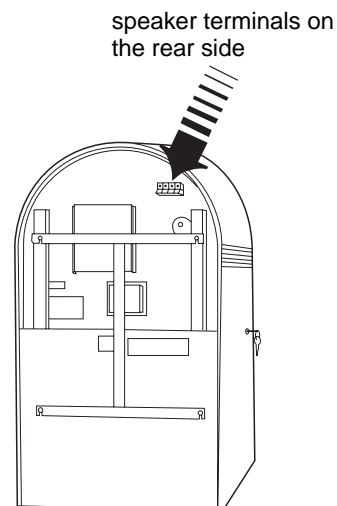

## 1.6 Power on



**NOTE:** Make sure that power outlet is grounded properly.

Insert the power plug. Set the power switch on the L.H. side of the jukebox to on. The illumination will light. The selection sledge starts an initialisation run and the counting of the disc compartments can be watched in the display. If all compartments are recognized the display shows "6 1 6 1" for short time. After all the sledge stops in its home position. The digital display shows the most played track. If the box is brandnew and the selection memory empty the display shows "0 0 0 0".

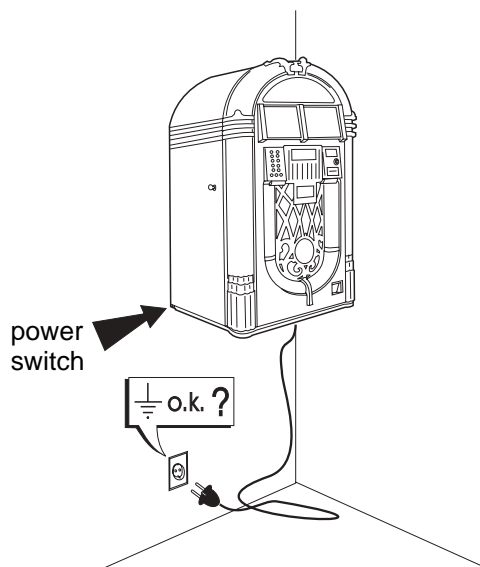



## 2 Loading compact discs

### 2.1 Position of CDs in the magazines

Up to 120 CDs can be inserted in total. The left magazine contains all CD's with odd compartment numbers (01, 03, 05 ...), the right one contains all even numbers (02, 04, 06 ...). But only 100 CDs can be selected in normal operation. (CD-no. 01 to CD no. (1)00 ). The CDs number 101 - 120 you can use only for Back Ground Music.

You have to update the 'number of CDs in the magazines' in service level 1 button 5 if you insert less than 100 CDs (100 CDs = factory pre-setting).

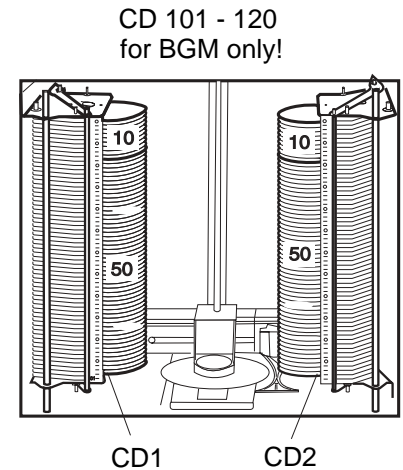

### 2.2 Remove magazines

You can pull out the magazines separately. By pushing the latch bar (1) inwards the magazine is released. At the same time the CDs are locked into place. Pull the handle bar (2) to remove the magazine completely.

When you insert the magazine the latch bar clicks into place and releases the CDs.



**NOTE:** In theory it is possible to use only one magazine. In this case the empty one has to be removed and the jukebox needs to be switched off and on once. After the initialisation run all selections belonging to the missing magazine are disabled. If e.g. the RH magazine is missing, all even selections are disabled. If an even number is selected the digital display will flash.

You can lay the magazine on its back side. Note, that the left magazine contains all CDs with odd numbers, the right one all with even numbers. Insert the CDs starting with the compartment 01, in the LH magazine then insert the second CD into compartment 02 which belongs to the RH one etc.. The CD label has to face upwards.



**ATTENTION!** Always push the magazine into its frame until the latch bar clicks into place properly!

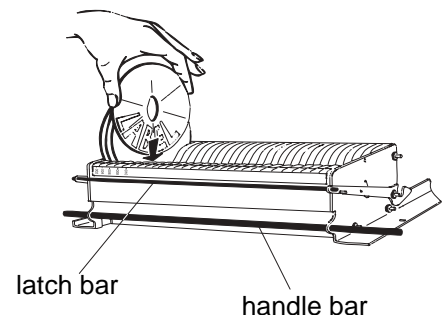
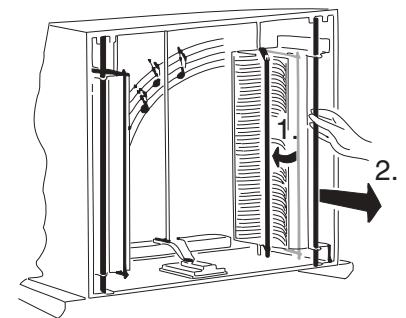

### 2.3 CD handling precautions - CD and player cleaning

Dust, fingerprints or other dirt on the disc surface can cause skipping, jumping or sticking problems.

Because of this never touch the surface of a disc! However it is rather easy to remove nicotine, dust or fingerprints.

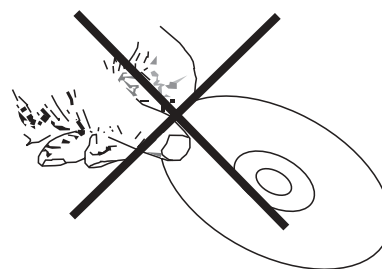

#### Nicotine, dust, fingerprints:

Dust can be removed with a lintfree soft cloth. If necessary, remove heavy dirt or fingerprints with a moistened soft cloth soaked in a solution of water and a detergent. Never use record cleaning sprays or anti static sprays! Furthermore, do not use other types of cleaners containing benzene, thinner or other solvents. These liquids will cause damage to the surface of discs. Move the cloth from the inside towards the outside and not in circular motion.

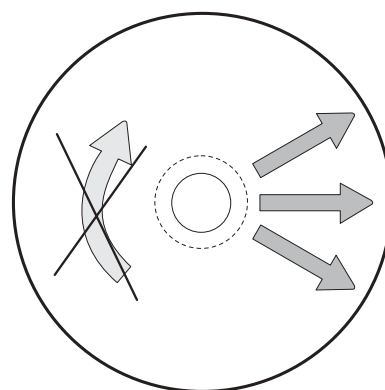

#### Removing scratches:

Use a soft cloth and a soft polish.

#### Laser lens cleaning:

Smoke and dust soils the lens. It can be cleaned with a cue-tip soaked in a detergent (i.e. Kodak Lens Cleaner, part no. 0051735). Place the tip on the lens and press down carefully.

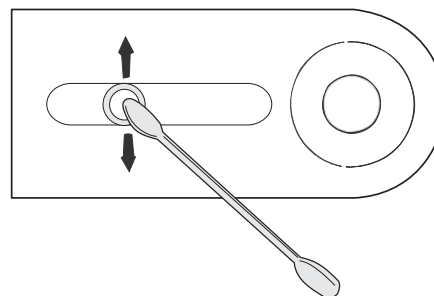

**ATTENTION!** The whole laser unit is very sensitive!

- Move the cue-tip only in the direction shown in the picture (perp. to the sledge direction).
- Do not scratch the special treated surface of the lense.
- Take care that the cleaning solution will not run into the focus unit.
- Keep away metal parts from the lens unit. A strong magnet is located underneath the lens. It attracts also smallest metal parts and so can block the complete unit.

## 2.4 Inserting title cards

After inserting the CD it is recommended to insert the appropriate title card into the paternoster book at the same time. Run through the book pages by means of the two push buttons.

To remove the cabinet lid bend both springs to outside.

Now you can take out each page.

Insert the title cards as shown in the picture. After inserting a page turn it forward and backward once to check its proper function.

If the page system works properly the red LED lights continuously. A blinking LED indicates the following errors:

- 1x - LH light gate indicates an error, or is defective
- 2x - Lead through gate indicates an error, or is defective
- 3x - RH light gate indicates an error, or is defective
- 4x - no or too slow page transport
- 5x - no zero page identification

LED blinks continuously: BCD-switch adjustment out of range 0 to 120.

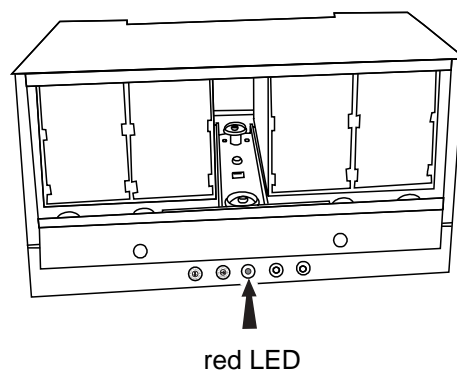
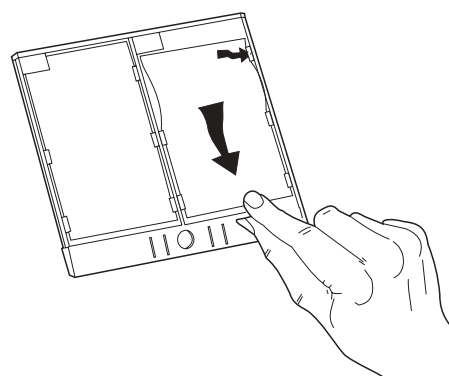
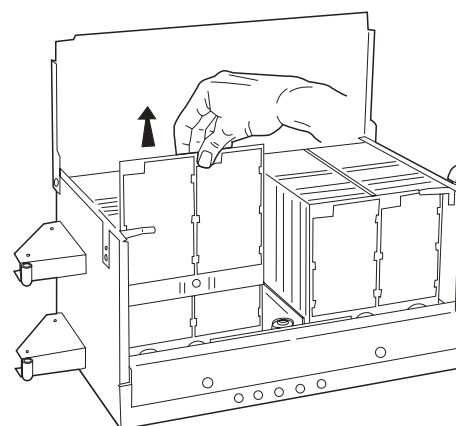
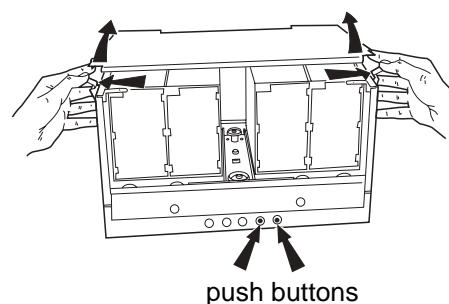

## 2.5 Programming number of CDs in the magazines

### Level 1, button 5

You have to update the 'number of CDs in the magazines' and make page limitation adjustment if you insert less than 100 CDs (factory pre-setting) or after a change of the number of inserted CDs .

If the number of CDs is programmed correctly the display will flash when you select an empty compartment. A flashing display indicates an 'empty' selection or no credit.

On the RH wall inside of the jukebox cabinet the so-called Selection & Credit Computer (SCC unit) is situated. On it you can find the switch "SERVICE" and the button "LT".

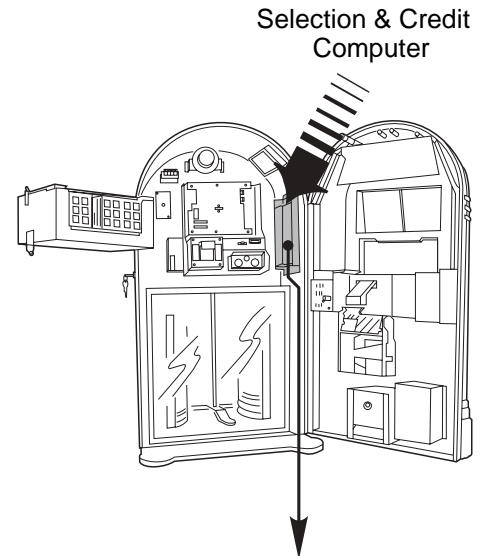

#### To program the number of inserted CDs (service level 1):

1. Set the slide switch 'service' at the SCC-unit to ON.
  2. Press 'LT' button.
  3. Press selection button R -hold down- and press selection button 0 then release both buttons.
  4. Press selection button 1. Service level 1 is reached. Display is: 1\_ \_ \_.
  5. To check the current setting press button 5, the display shows e.g. 50 or 00.
  6. To reprogram press selection button 5 -hold down- and press selection button R. Enter the desired number of CDs with two digits (enter 00 for 100 CDs).
- To check the new settings, press button 5 again.

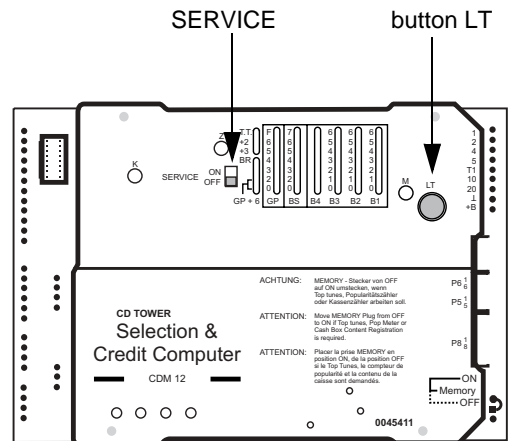

#### Exit the service program:

1. Set the slide switch 'service' at the SCC unit to OFF.
  2. Press 'LT' button.
- The changer starts an initialisation run. After this the jukebox is ready to operate.

## 2.6 Adjustment of the page limitation

If less than 100 CDs are installed it is useful to disable the not needed pages. It will be done by two BCD switches at the front side of the book.

For easy handling you can use the table below to adjust the two switches.

Nevertheless you will find here an example how to calculate the BCD switch adjustment.

The switch BCD1 has a valency of 16, the other one, BCD2 a valency of 1. The meaning of the characters is according to the hexadecimal character set:

A = 10      B = 11      C = 12  
D = 13      E = 14      F = 15.

If you want to adjust a number of 60 CDs divide 60 by 16.

It equals 3,75. The number before the decimal point has to be adjusted at BCD1. Ignore the numbers after the decimal point. After this multiply the adjusted number 3 by 16. It equals 48. Subtract this number from the given number 60. This equals 12. Adjust this number at BCD2 as „C“ (=12) according to the hexadecimal character set.

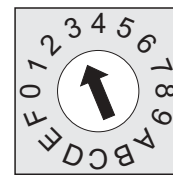
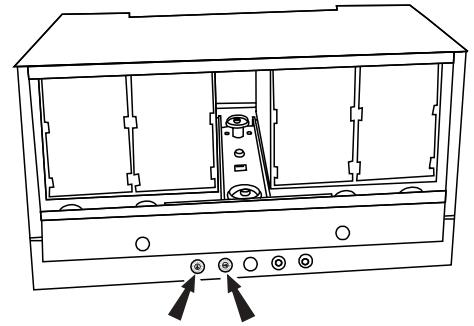

BCD1

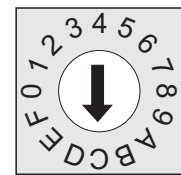

BCD2

Pages	BCD1	BCD2	Pages	BCD1	BCD2	Pages	BCD1	BCD2	Pages	BCD1	BCD2	Pages	BCD1	BCD2
1	0	1	26	1	A	51	3	3	76	4	C	101	6	5
2	0	2	27	1	B	52	3	4	77	4	D	102	6	6
3	0	3	28	1	C	53	3	5	78	4	E	103	6	7
4	0	4	29	1	D	54	3	6	79	4	F	104	6	8
5	0	5	30	1	E	55	3	7	80	5	0	105	6	9
6	0	6	31	1	F	56	3	8	81	5	1	106	6	A
7	0	7	32	2	0	57	3	9	82	5	2	107	6	B
8	0	8	33	2	1	58	3	A	83	5	3	108	6	C
9	0	9	34	2	2	59	3	B	84	5	4	109	6	D
10	0	A	35	2	3	60	3	C	85	5	5	110	6	E
11	0	B	36	2	4	61	3	D	86	5	6	111	6	F
12	0	C	37	2	5	62	3	E	87	5	7	112	7	0
13	0	D	38	2	6	63	3	F	88	5	8	113	7	1
14	0	E	39	2	7	64	4	0	89	5	9	114	7	2
15	0	F	40	2	8	65	4	1	90	5	A	115	7	3
16	1	0	41	2	9	66	4	2	91	5	B	116	7	4
17	1	1	42	2	A	67	4	3	92	5	C	117	7	5
18	1	2	43	2	B	68	4	4	93	5	D	118	7	6
19	1	3	44	2	C	69	4	5	94	5	E	119	7	7
20	1	4	45	2	D	70	4	6	95	5	F	120	7	8
21	1	5	46	2	E	71	4	7	96	6	0			
22	1	6	47	2	F	72	4	8	97	6	1			
23	1	7	48	3	0	73	4	9	98	6	2			
24	1	8	49	3	1	74	4	A	99	6	3			
25	1	9	50	3	2	75	4	B	100	6	4			

### 3 Coin operation or free play?

Both coin operation or free play are adjustable at the "Selection & Credit Computer"-unit. It is located at the RH side of the cabinet. Special jumpers (short wires, located in the accessory pack of the manual ) are used to set prices on the SCC-unit. As long as no jumper is set in row GP from 0 to F and the jumper in row GP+6 is not removed (free play) the jukebox works with coins only.

#### 3.1 Coin operation

From factory the jukebox is set to coin operation. If you insert a certain number of coins according the denomination label, the jukebox gives the credits or plays it is adjusted for. If you want to change the play prices you have to change the jumper settings on the SCC-unit.

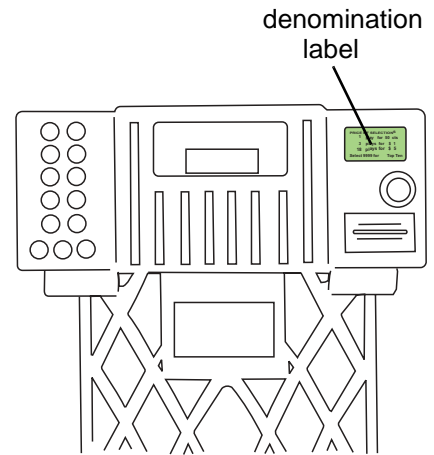

#### 3.2 Free play

To set the jukebox to free play:

1. Remove all the jumpers on the SCC unit taking note of current setting for future reference.
2. Set a jumper from 0 to F (free play) in the row GP on the S&CC unit.
3. Press 'LT' button.
4. Now **one track** is selectable without coin insertion.
5. From **two to six tracks** are selectable by setting an additionally jumper in the row 'BS' (Bonus Step) from 0 to 2 up to 0 to 6.
6. **Up to 47 tracks** are pre-selectable by setting a jumper in this row 'BS from 0 to 7.

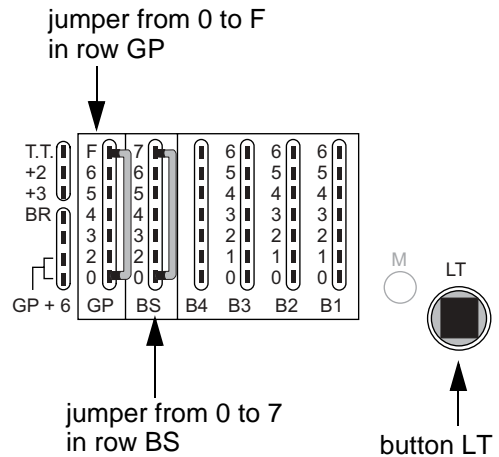

### 3.3 Test credit

For repair and test purposes it is possible to give test credits. By touching the test credit button (in special cases several times) you get one credit also shown in the digital display. You can terminate unused credits by pressing the LT button.

In jukeboxes with an electronic coin validator you can find the test credit button on the coin validator interface board.

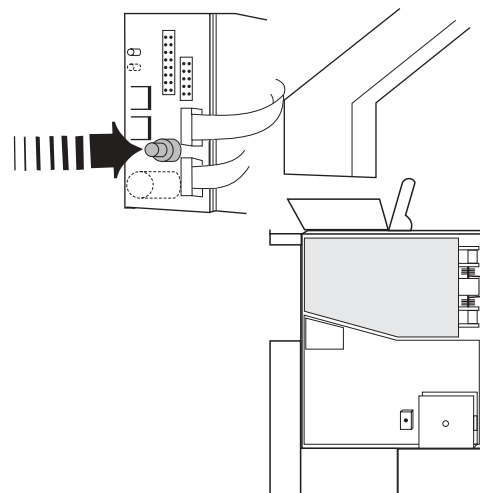

In jukeboxes with mechanical coin validator the test credit button is mounted above the return lever inside.

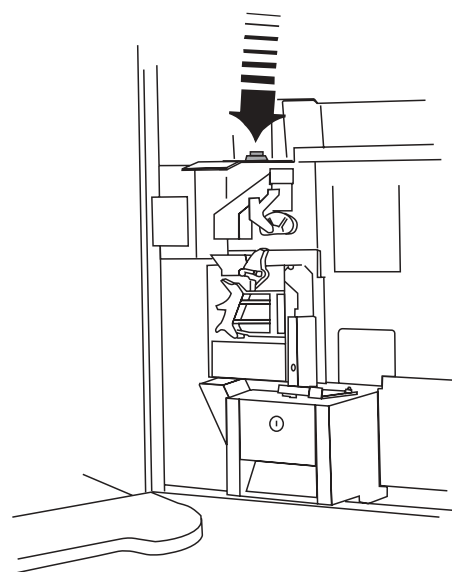

## 4 Track selections

### 4.1 How to select a track

If credit exists or free play is set you can select tracks by means of the buttons 0 - 9 of the keyboard.

First enter the number of the CD with two digits, then the track number with two digits too. (track numbers higher than 35 will not be accepted).

Example: CD 2, track 9: Enter 0 - 2 - 0 - 9.

(Exception: CD 100 = 00.)

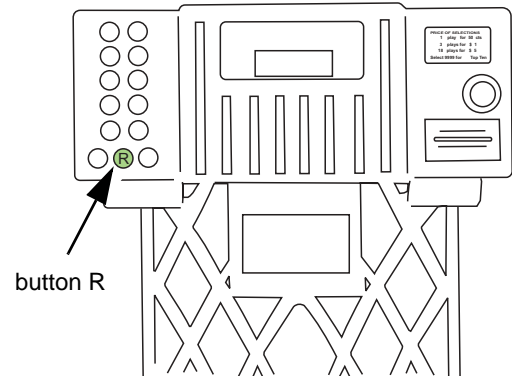

#### The button R

You can delete wrong entered numbers up to the third digit by means of the button R (Reset). But after having entered the fourth digit the jukebox stores and executes a selection also made by mistake. By pressing the button R the available credit will be displayed for a few seconds.

#### The display flashes

After entering the fourth digit of a selection the jukebox starts to search and play the selected CD immediately. If the display flashes the entered selection was not valid. Check:



- if credit is available
- if the selection is higher than the programmed number of CDs in magazines

If you select a higher track number as available on a CD, the jukebox overcounts the tracks and starts at the beginning.

Example:

CD 03 contains 17 tracks. But selected track is 0 - 3 - 1 - 9. The jukebox plays track 02 of CD 03.

**Maximum 35 tracks per CD can be selected!**



## 4.2 I do not like this track - the button CANCEL

If you do not like a track you can either cancel it by pressing the button 'CANCEL' at the control box inside the jukebox or at the infrared remote control. The jukebox stops playing or plays the next track if a selection has already been made.

You can terminate all selections only by pressing the button LT on the SCC unit .

You can loosen the control box inside the jukebox to use it as an external wire remote control. Its 10-line ribbon cable may be extended as required with any kind of wire .

As an option it is possible to connect two wired remote controls in parallel or one wired remote control together with one infrared remote control.

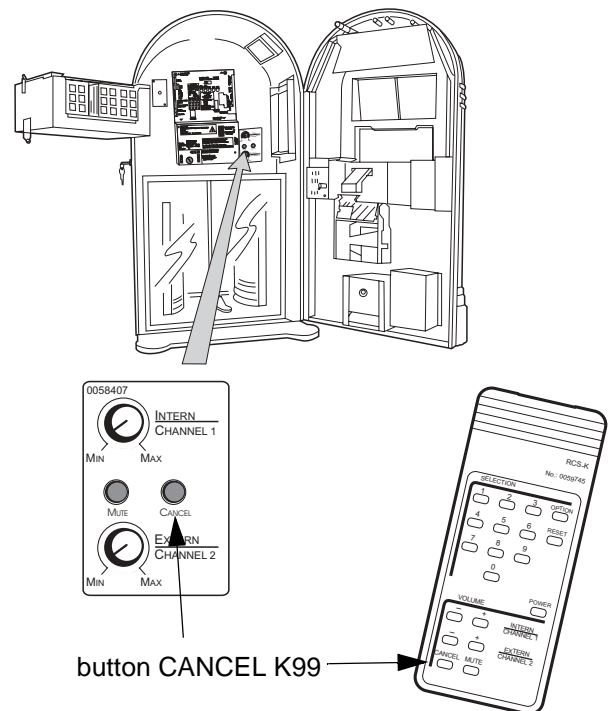
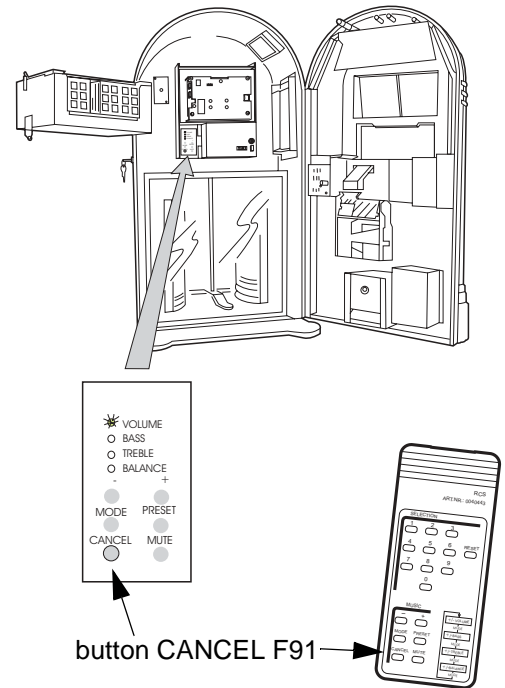

### 4.3 Albumplay - playing a whole CD

You can select a whole CD by entering the CD number followed by two times 0, provided that 'Albumplay' is enabled and the SCC has reached the fourth bonus level or if free play is set.

**Programme:**

To enable 'Albumplay', enter the service level 1:

1. Set the slide switch 'service' at the SCC unit to ON.
2. Press 'LT' button.
3. Press selection button R -hold down- and press selection button 0 then release both buttons.
4. Press selection button 1. Service level 1 is reached. Display is: 1\_ \_ \_.

To enable 'Albumplay' press selection button 9 -hold down- and press selection button R. Release both buttons. Enter 01 to enable (or 00 to disable) 'Albumplay'.



**ATTENTION!** If you press the CANCEL button while a complete CD is playing as long as the last track is not reached the next track on this CD will be played.

**Exit the service program:**

1. Set the slide switch 'service' at the SCC unit to OFF.
  2. Press 'LT' button.
- The changer starts an initialisation run. After this the jukebox is ready to operate.

## 5 Automatic random select

If the playstimulator is switched on by means of the continuous play switch or the service program the jukebox plays random tracks of the registered CDs in the magazines (service program level 1 button 5). CDs declared as BGM CDs will not be used, [refer to chapt. 9.4 on page 31!](#)

The volume is the same as in normal operation. If a selection is made the playstimulator will be interrupted immediately and remains after having played the selected tracks.

You can programme the playstimulator by software too. Then the time between the random tracks of the playstimulator is programmable between 1 up to 98 min. You may also programme a time window in which the playstimulator works, [refer to chapt. 9.3 on page 29.](#)

On jukeboxes with F91 amplifier or without remote controls you can switch on CONTINUOUS PLAY with the continuous play switch. Part number is 0034410. It has to be connected to P8 of the SCC unit.

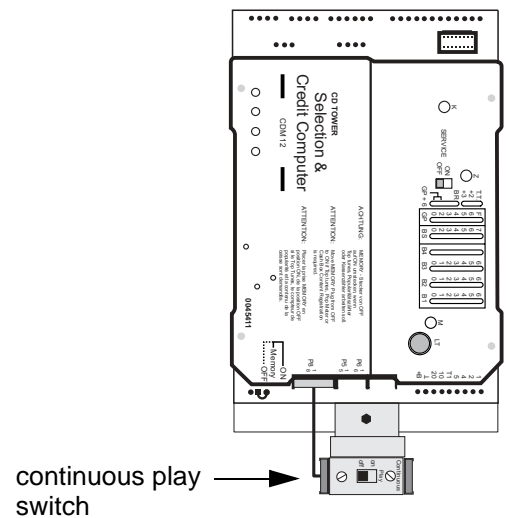
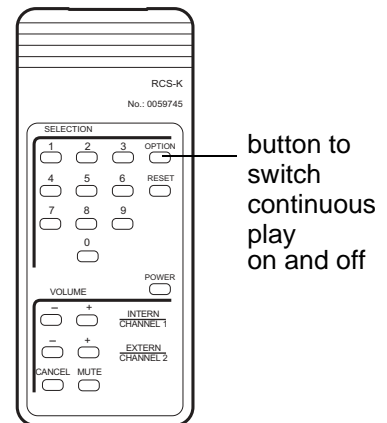

## 6 Volume, sound and balance control

### 6.1 Volume, sound and balance control - amplifier F91

With the control terminal inside of the jukebox the volume, treble, bass and balance can be controlled individually.

After power up or if no button has been pressed for approx. 5 sec or after the button PRESET has been pressed, the terminal stays in the mode "VOLUME". The LED "VOLUME" lights. In this mode you can control the volume by means of the buttons '+' and '-'. (Adjustments return to preset after power off.)

One LED corresponds to each mode. Use 'mode' button to activate desired mode. With the buttons '+' and '-' treble, bass or balance can be controlled.

The control terminal can be taken out and be used as a wired remote control.



**ATTENTION!** Depending on the adjusted volume of the jukebox loudness levels of more than 70 dB can be reached.

#### The meanings of the buttons...

- VOLUME:
  - Volume LED lights.
  - + button increases volume
  - - button decreases volume.
- BASS: (Press 'MODE' button once.)
  - Bass LED lights.
  - + button increases bass volume
  - - button decreases bass volume.
- TREBLE: (Press 'MODE' button twice.)
  - Treble LED lights.
  - + button increases treble volume
  - - button decreases treble volume.
- BALANCE: (Press 'MODE' button 3 times.)
  - Balance LED lights.
  - + button increases right hand channel volume and decreases left hand channel volume
  - - button decreases right hand channel volume and increases left hand channel volume.

**MODE:** Switches to the next operating mode. After about 5 seconds without operating any buttons, 'volume' mode is resumed.

**PRESET:** Volume, bass, treble, and balance are set to the preset according to DIP switch setting. Actual mode is set to 'Volume'.

**CANCEL:** Rejects a playing track. If album play is selected the next track will be played.

**MUTE:** As long as this button is activated, the amplifier output is muted.

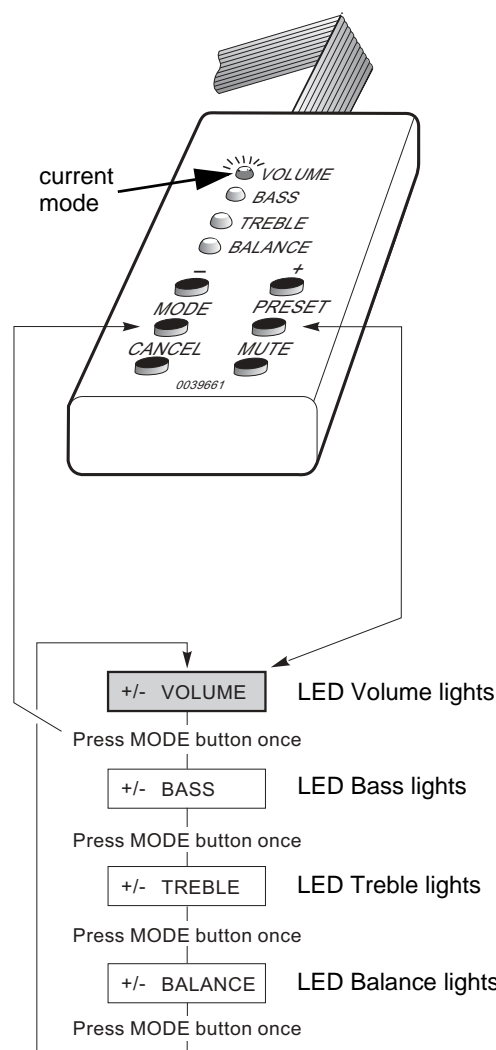



**ATTENTION!** After power off all adjustments are reset to dip switch settings. For permanent adjustment e.g. treble, bass use the dip switches.

The control terminal inside of the jukebox can be taken out and be used as a wired remote control. If required its 10-line ribbon cable may be extended with any kind of wire. The voltage of the control wire is 5V DC.

It is possible to connect two wired remote controls in parallel or one wired remote control together with one infrared remote control. The control mode is displayed with 4 LEDs. The mode can be changed by using the 'mode' button to control volume, bass, treble and balance:

### The infrared remote control

As desired an infrared remote control will be installed from factory or can be delivered as conversion kit (part no. 40435). If it has been installed the hand transmitter is located in the cash-box.

If credit is given or free play is programmed a CD can be selected with the buttons 0 to 9 and R.

Double button functions as required in the service programs (i.e. press button 5 -hold down- and press button R), are impossible. For this you only can use the keyboard of the jukebox.

The meanings of the music control buttons are according to the buttons on the control terminal on the rear side of the jukebox (ref. to the prev. section).

The receiver eye of the infrared remote control is located behind the plastic on the top RH front side of the door. Beam this point directly if possible.

Batteries are included. Necessary are 4 micro cells type LR03 (AAA). To open the battery compartment move the cover like shown in the picture. Needed battery type and position of the batteries in the hand transmitter are shown on the casing. Part no. of the hand transmitter: 0040443.

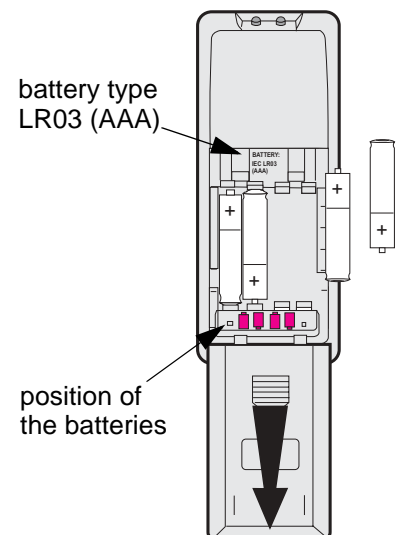
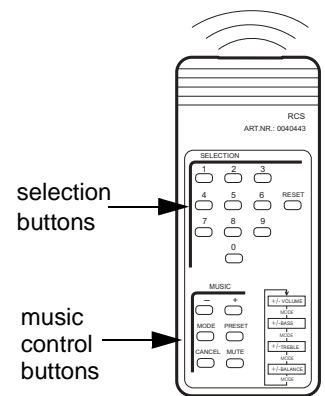

## 6.2 Volume, sound and balance control - amplifier K99

### Volume control

You can control the volume of the jukebox from different points at the same time:

- With the pots Vol.1 and Vol.2 on the amplifier.
- With the IR remote control.
- With the pots of the control box at the rear side of the jukebox.

The device from which the volume is changed determines it.

The volume control unit can be taken out and may be mounted at another place as a remote control. Its cable may be extended as required with any kind of wire. The voltages of the control wires are 5V DC.

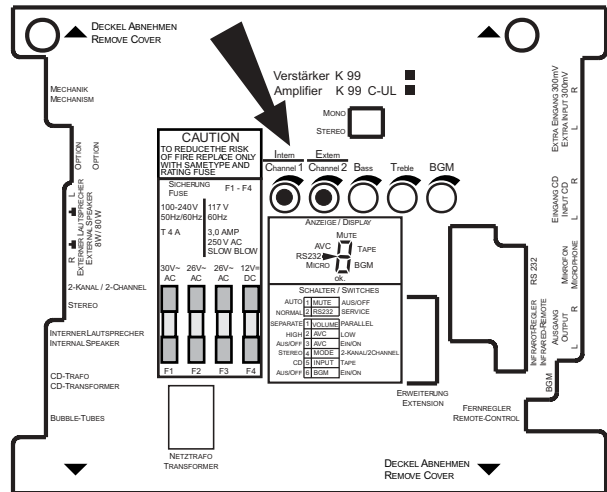

The control box has two volume knobs (Intern / Channel 1 and Extern / Channel 2). In position "Stereo" the knob "Intern / Channel 1" is effective for the internal speakers. The knob Extern / Channel 2 is controlling the volume of the RCA outputs for an optional external amplifier. In DIP switch position "2 Channel" the channels1 (RH) and 2 (LH) are controlled separately.



**ATTENTION!** The pots Vol. 1 and Vol. 2 on the amplifier are not effective if the wire control box is connected.

### Treble and bass control

You can control the sound with the knobs bass and treble on the amplifier.

### Automatic volume control

The AVC sets CDs with different volume levels to an equal level. The level of CDs with a high level will be reduced; the level of low-levelled CDs will be increased. This control works rather slow to save the dynamic range of the track. You can enable the correction with the DIP switch "AVC" (the 3rd DIP switch of the 6 sw. group). Default is AVC disabled.

With the second DIP switch of the 6 sw. group you can reduce the intensity of volume correction.

### The infrared remote control

An infrared remote control is installed from factory in every Princess. It can also be delivered as conversion kit (part no. 0058809). If it has been installed the hand transmitter is located in the cash box.

If credit is given or free play is programmed a CD can be selected with the buttons 0 to 9 and R.

Double button functions as required in the service programs (i.e. press button 5 -hold down- and press button R), are impossible. For this you only can use the keyboard of the jukebox.

You can control the volume by means of the buttons + and -. In stereo mode the internal +/- buttons control the volume of the internal speakers. The external +/- buttons control the volume of the K99 RCA jacks for an optional external amplifier. In 2-channel mode you can control the external speakers by the buttons + and - of the external channel.

Beam the jukebox directly if possible.

You can connect the wire remote control box as well.

The power-on volume level is always set by the channel 1 and 2 pots on the amplifier or on the control box (if connected).

Batteries will be delivered. Necessary are 4 micro cells type LR03 (AAA).

To open the battery compartment move the cover like shown in the picture.

Needed battery type and position of the batteries in the hand transmitter are shown on the casing.

Part no. of the hand transmitter: 0059745.

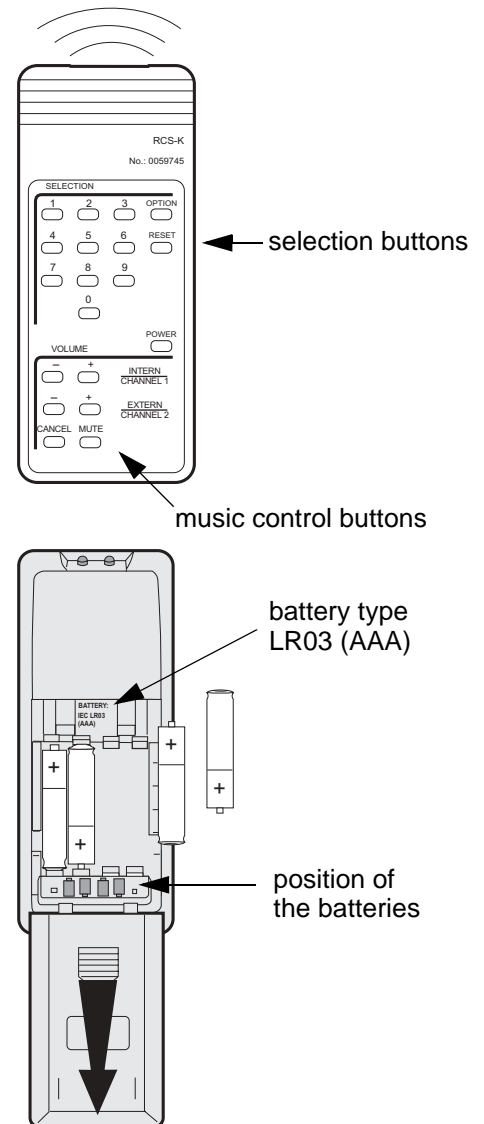

# 7 Coin and price settings

## 7.1 Price settings

Usually the prices are preset by the factory according the denomination label. In the "Unipack" version no play prices are preset. To set the play prices do the following steps:

1. Switch on the jukebox.
2. Coin output plugs (1) should be set according an separate attached instruction by connecting to the pin row (2) on the SCC unit. Pay attention to wiring colors (refer to [chapt. 7.4 on page 23](#)).
3. Set the attached jumpers in B1 to B4 according to the number of the desired additional bonus plays. (3).
4. Press „LT“ button once (4) to accept the new price/bonus setting.

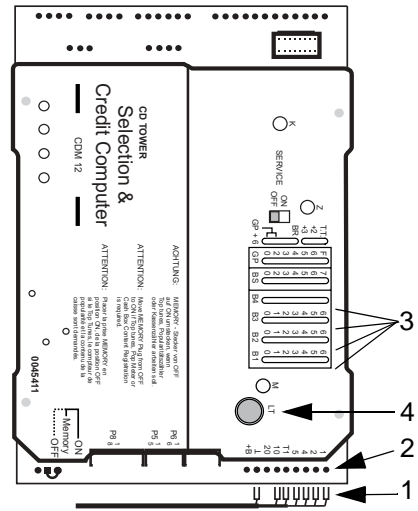

## 7.2 Examples

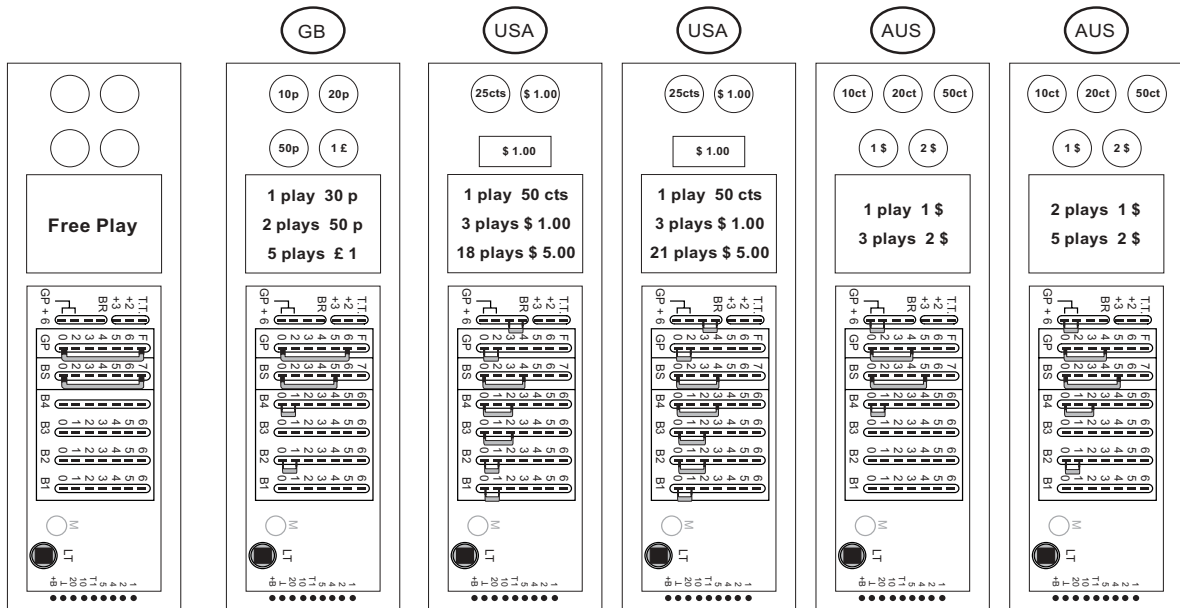



### 7.3 Free play programming

Set a jumper from 0 to F (free play) in the row GP on the SCC unit and be sure that jumper GP+6 is removed. Then press 'LT' button.

Now one track is selectable without coin insertion.

In between two to six plays are selectable by setting an additionally jumper in the row 'BS' (Bonus Step) from 0 to 2 or from 0 to 6.

Up to 47 tracks are pre-selectable by setting a jumper in this row 'BS' from 0 to 7.

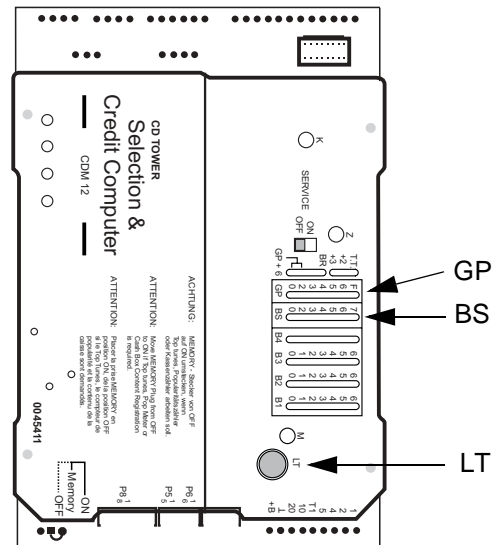

### 7.4 Color codes of coin input

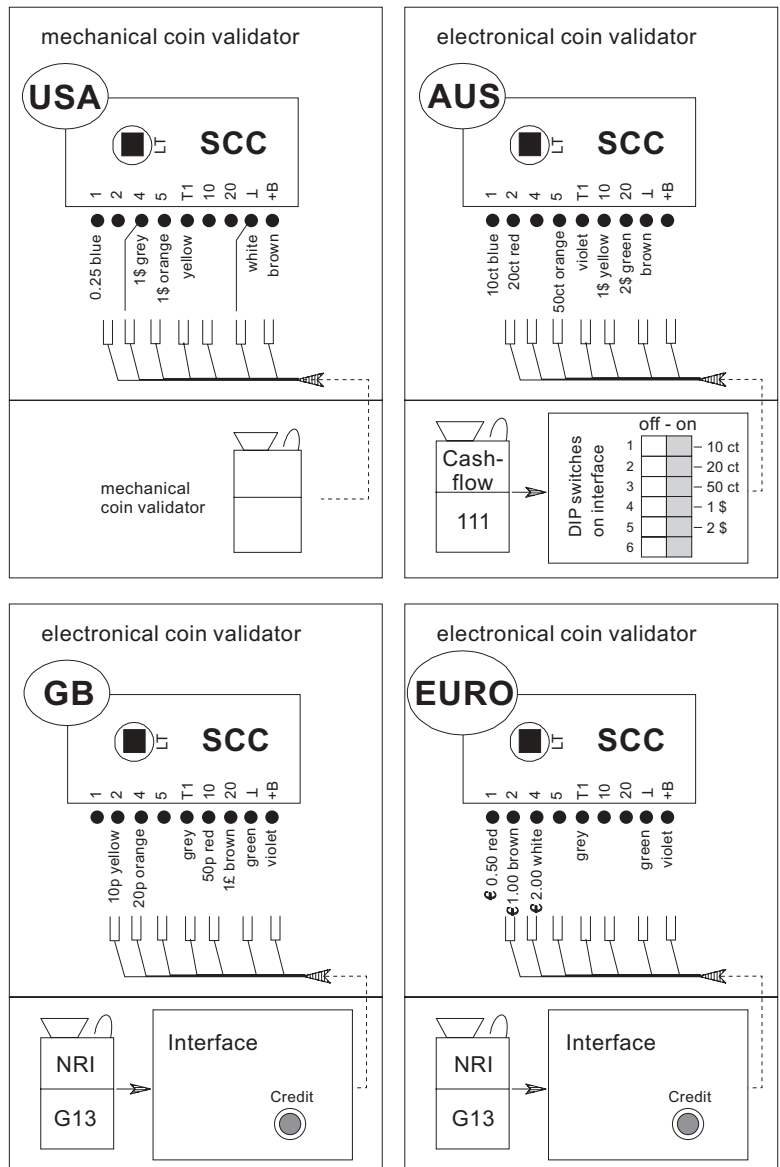

## 7.5 Selecting, displaying and programming of top tunes

You can select the most played tracks (top tunes) by selecting 9999 in the normal operation mode, provided that the 2nd bonus step (B2) of the jukebox is reached by coin insertion. The total number of played tracks depends on the bonus price settings of the first two bonus levels (B1 and B2, ref also to chap. 1.6). In addition to this setting the jukebox plays one track more.

After having reached the bonus level 2 the SCC unit gives 7 credits (4 basic credits in total + 1 bonus credit from B1 + 2 basic credits from B2 = 7 credits total). If you select the top tunes with 9999 the jukebox plays one track more (= 8 tracks).

If you set an additional jumper from TT (Top Tunes) of the SCC unit to +2 the jukebox plays two additional tracks (in our example 9 tracks).

If you set a jumper from TT to +3 the jukebox plays 3 additional tracks (in our example 10 tracks).

To find out which tracks will be played after selecting 9999 you can display the tracks by entering 9998. At first the most played track will be displayed. Then you have to enter 9998 again and the jukebox shows the second most played track etc. To display the tracks the SCC unit needs about 2-3 sec for calculation. If the display starts to flash press the selection button R once.

As example we use the US price settings  
50cts 1 play, \$1.00 3 plays, \$5.00 21 plays

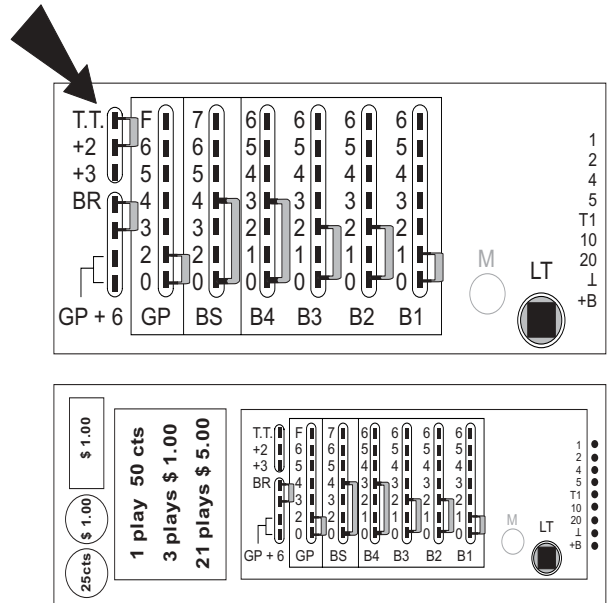

Price settings:

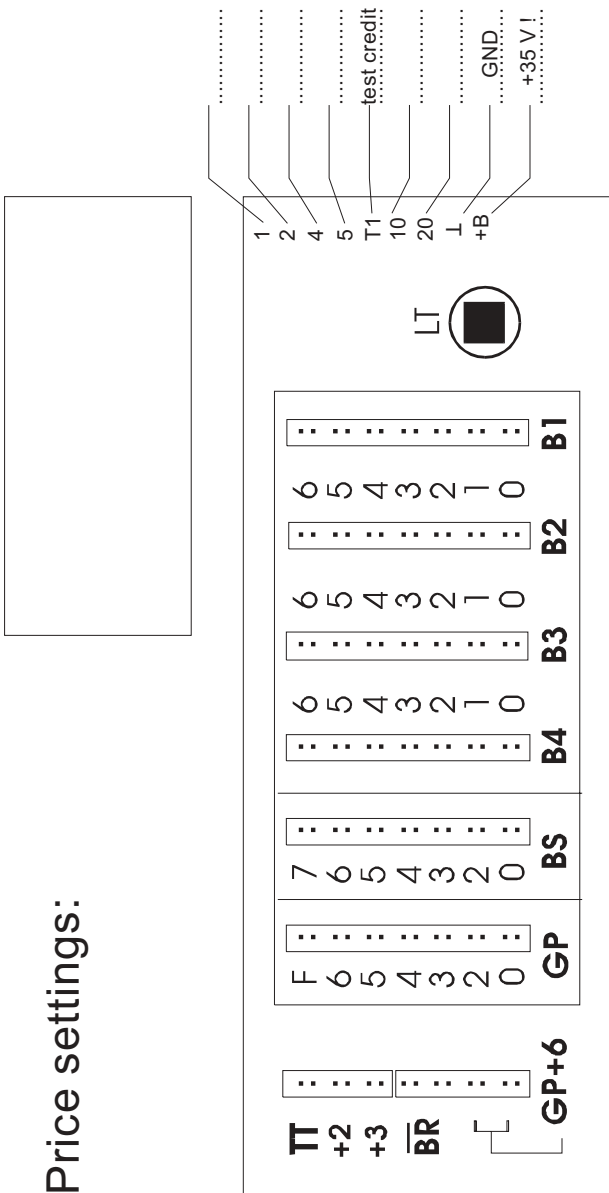

	1.	2.	3.	4.	5.	6.	7.	8.	9.	10.	11.	12.	13.	14.	15.	16.	17.	18.	19.	20.	21.	22.	23.	24.	25.
pulse																									
inserted money																									
plays from GP:																									
from bonus step																									
plays B1...B4																									
total plays																									

# 8 Programming short view

OPERATING INSTRUCTIONS

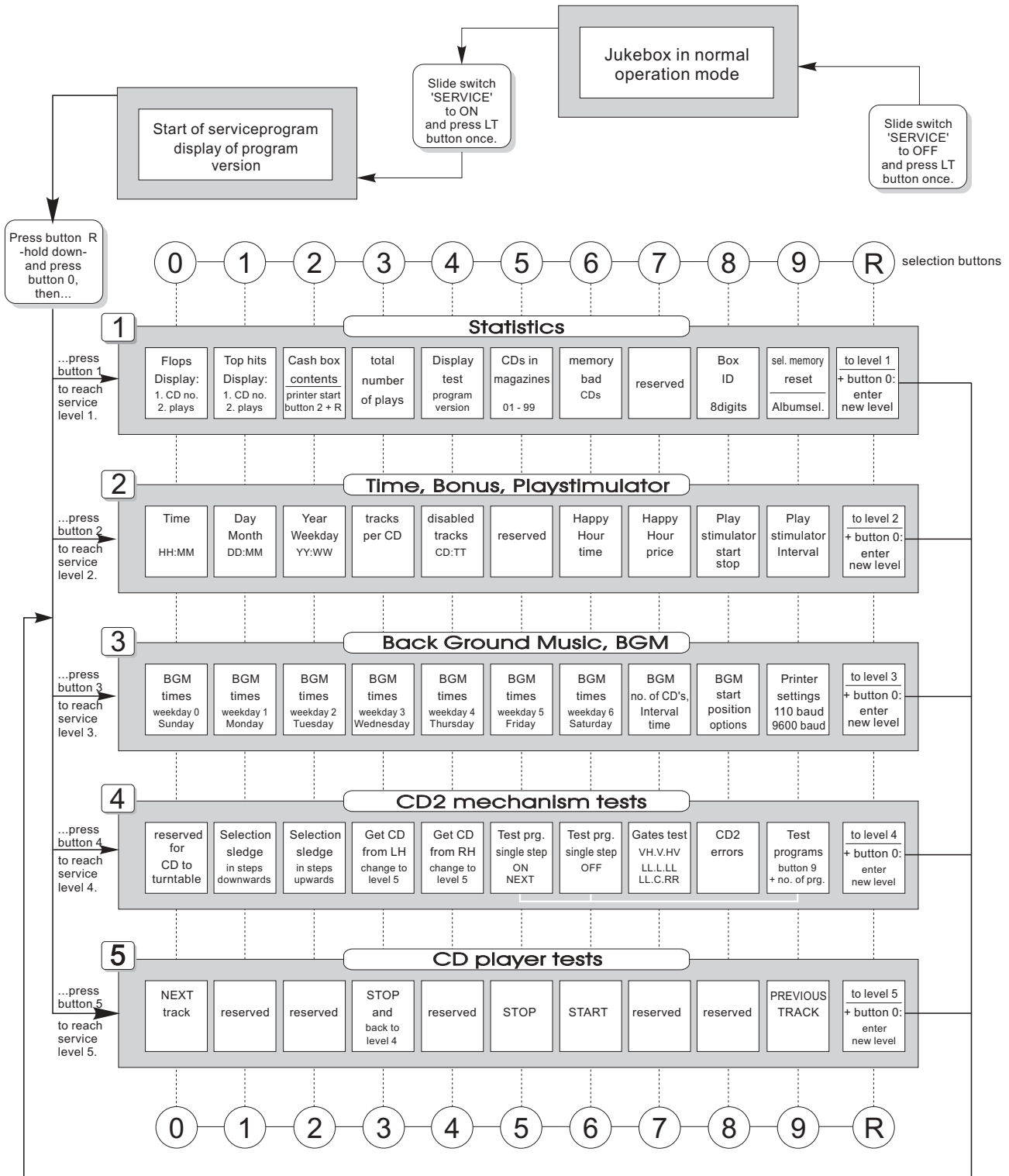

**Programming:** Press according button - hold down - and press selection button R , release both buttons and enter the new value.

## 9 Jukebox programming

Additional features like Playstimulator, BGM time and Happy Hour time are programmable. These features are programmable in the service mode of the SCC unit.

### 9.1 Calling service programs

**Hint:**

To keep the data stored when power is off the plug "Memory" must be set to "ON" position on the SCC unit, otherwise all programmed data in service levels are reset when power is interrupted.

**Calling service programs:**

Set slide switch "Service" from position OFF to ON, then press the LT button. After an initialization run the display will show the actual jukebox (SCC) program version (e.g.: in the display 4.09) and gives a message whether the magazines are installed properly.



**Calling service levels:**

By pressing the LT button. The display shows the actual service level number in the LH digit. Each option can be called by pressing the corresponding selection button.

**Calling a certain service level (recommended method):**

Press selection button R - hold down - and press selection button 0. Release both buttons. The display is dark.

Enter the number of the desired service level.

**Exit:**

Set the slide switch 'SERVICE' to OFF and press the LT button once.

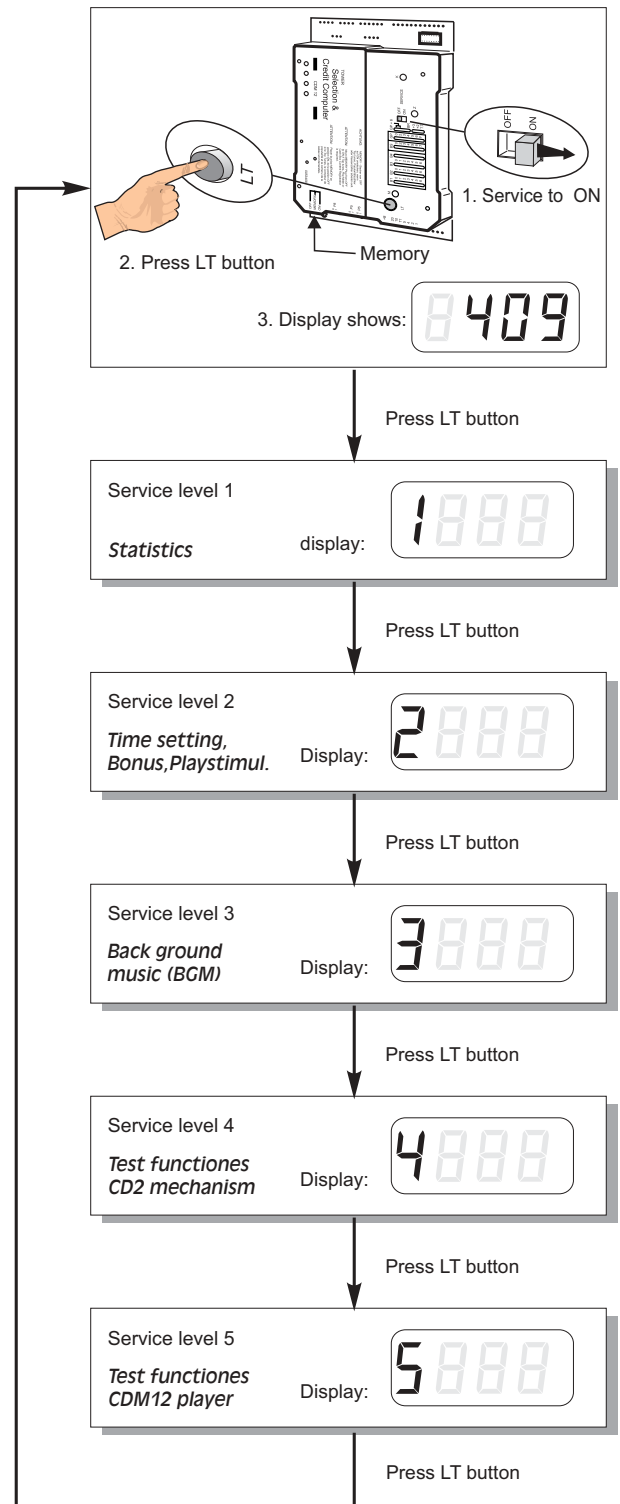

OPERATING INSTRUCTIONS

## 9.2 Programming of time functions

### Level 2

It is necessary to program the time, date and weekday once or at least to control these settings. Only then the jukebox can switch on and off the playstimulator or the Back Ground Music at the desired time. It is useful to program time, date and weekday in a single pass.

To program the time (and also the date):

1. Set the slide switch 'service' at the SCC-unit to ON.
2. Press 'LT' button.
3. Press selection button R -hold down- and press selection button 0 than release both buttons.
4. Press selection button 2. Service level 2 is reached. Display shows: 2\_ \_ \_.

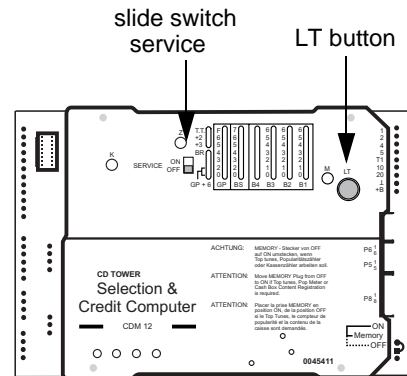

### 9.2.1 Clock setting, level 2 button 0

Press selection button 0. The display shows the current time.

If the displayed time is not correct:

Press selection button 0 -hold down- and press selection button R. Release both buttons. Enter the correct time with four digits.

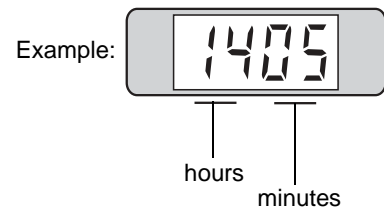

### 9.2.2 Set date, level 2 button 1

Press selection button 1. The display shows the current date.

If the displayed date is not correct:

Press selection button 1 -hold down- and press selection button R. Release both buttons. Enter the correct date with four digits.

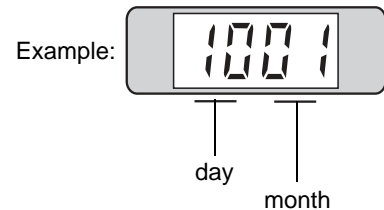

### 9.2.3 Set year and weekday, level 2 button 2

To display the year and the weekday press selection button 2:

The weekdays are assigned to numbers as shown.

- |               |              |
|---------------|--------------|
| 0 = Sunday    | 4 = Thursday |
| 1 = Monday    | 5 = Friday   |
| 2 = Tuesday   | 6 = Saturday |
| 3 = Wednesday |              |

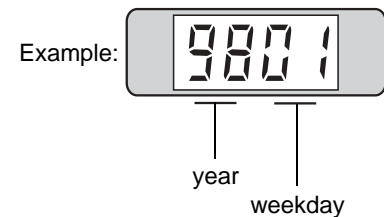

To program press selection button 2 -hold down- and press selection button R. Release both buttons. Enter the correct year with two digits, then enter a 0 followed by the number of the weekday.

### Exit the service program:

1. Set the slide switch 'service' at the SCC unit to OFF.
2. Press 'LT' button.
  - ⇒ The changer starts an initialisation run. After this the jukebox is ready to use.

### 9.3 Programming of the Playstimulator (random selections without coin insertion)

In service level 1 button 5 the actual number of CDs in the magazines is registered. If the playstimulator is programmed the jukebox plays random tracks of these CDs. Exception: CDs declared as BGM CDs will not be used! The time between the last track played by inserted money and the first random track of the playstimulator is programmable from 1 up to 98 min. This time is also the repeat time between two random plays.

The volume is the same as in normal operation. If a selection is made the playstimulator will be interrupted immediately. It starts again after all selected tracks have been played.

#### 9.3.1 Repeat time programming, level 2 button 9



**NOTE:** The playstimulator only works

- if Back Ground Music is not activated at the same time
- if time is programmed correctly
- if no credit is available

1. Set the slide switch 'service' at the SCC unit to ON.
2. Press 'LT' button. Display shows e.g.: \_ 4 0 9  
⇒ (409 or higher = SCC program version)
3. Press selection button R -hold down- and press selection button 0 then release both buttons. The display is dark.
4. Press selection button 2. Service level 2 is reached. Display shows: 2\_ \_ \_.
5. Press selection button 9. The display shows three digits.
  - ⇒ A = repeat time is set to 5 minutes
  - ⇒ B = This digit enables or disables the Playstimulator mode,  
0 = Playstimulator OFF,  
1 = Playstimulator ON

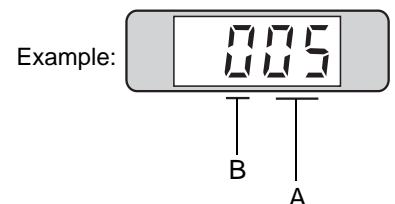

continuously playing of random tracks

#### Playstimulator operating modes:

You can set the jukebox in an easy way to CONTINUOUS PLAY MODE by programming the digit CONTINUOUS PLAY to '1'. An additional programming of the clock and the start and stop time is not necessary.

By means of an optional installed switch you can also switch the box to CONTINUOUS PLAY MODE without any need of entering the service program. Part number of this switch is 0034410. It has to be connected to P8 of the SCC unit.

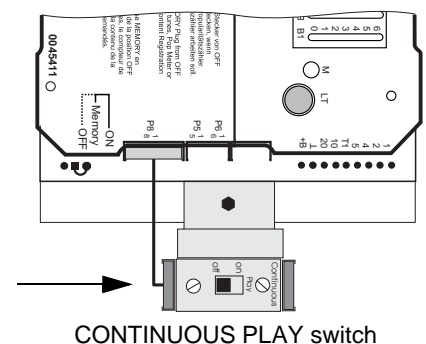

A more precise programming in conjunction with the internal clock and the start, stop and repeat time is possible if the digit CONTINUOUS PLAY is set to '0'. A correct programming of all these items is necessary.

NO random plays



Continuous random plays, however in conjunction with start and stop time.



After a played random track the jukebox waits about 5 minutes before it starts the next one. Random tracks will only be played in the programmed Playstimulator time interval. The programming of this 'time window' is described as follows.



To program press selection button 9 -hold down- and press selection button R. Release both buttons. Now enter the digit for CONTINUOUS PLAY and the REPEAT TIME with three digits.

To check the settings: Press button 9 again.

**9.3.2 Programming start and stop time, level 2 button 8**

Press selection button 8. The display shows at first a flashing 1. This means 'start time'.



Then the time will be displayed, here 14.05 o'clock (2.05 p.m.).



Press selection button 8 once again. The display shows now a flashing 2. This means 'stop time'.



Then the time will be displayed, here 18.30 o'clock (6.30 p.m.).



To reprogramme press selection button 8 - hold - and press selection button R. Release both buttons. The digital display goes dark. Enter the start and stop time with eight digits.

**Example:** The jukebox should play random tracks from 09.00 in the morning to 17.00 in the afternoon.

Enter: 0 - 9 - 0 - 0 - 1 - 7 - 0 - 0 (0900 = start time, 1700 = stop time)

Then press selection button R. The display shows 2 \_ \_ \_ .

To check the start time: Press selection button 8.

To check the stop time: Press selection button 8 again.



**NOTE:** You can not programme the playstimulator over 24.00 o'clock (e.g. 23.00 to 2.00 o'clock) !



**If the Playstimulator does not work:****Check if:**

- the clock is set correctly ?
- start and stop time is programmed?
- repeat time is set correctly (not 0)?
- BGM play mode is disabled (ref. to next chapter).
- credits are still in memory.

**Exit the serviceprogram:**

1. Set the slide switch 'service' at the SCC unit to OFF.
2. Press 'LT' button.  
The changer starts an initialisation run. After this the jukebox is ready to operate.

**9.4 BackGround Music (BGM), level 3**

If BGM is programmed and activated a random track from the CDs declared for BGM will be played. The time between the last selected played track and the first BGM track is programmable between 1 and 98 minutes. This time is also the repeat time between two BGM tracks.

The volume for BGM reproduction is reduced compared to the normal volume. It is adjustable with the two BGM pots (RH channel / LH channel) on the amplifier. BGM mode is active when the LED on the amplifiers lights. The source of the BGM control signal is the SCC unit plug brown (X6), pin 1. Once the BGM mode is activated, it is not possible to operate the Playstimulator.

If a selection is made by means of coin insertion the track being played will be interrupted immediately. Two intervals can be programmed for each weekday.

**To enable BGM (level 3):**

1. Set the slide switch 'service' on the SCC-unit to ON.
2. Press 'LT' button.
3. Press selection button R -hold down- and press selection button 0 than release both buttons.
4. Press selection button 3. Service level 3 is reached. Display shows: 3\_ \_ \_.

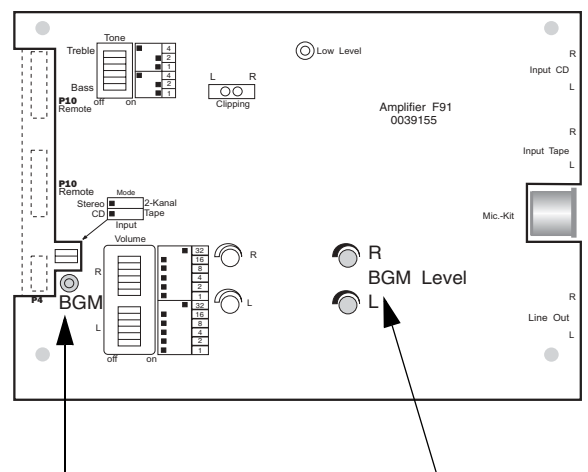

BGM light emitting diode (yellow), indicates whether BGM is active

pots to level the BGM volume

**9.4.1 Number of BGM CDs and repeat time, level 3 button 7**

Press selection button 7 the display shows e.g.:

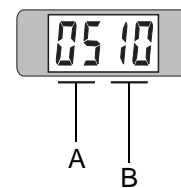

- A = number of BGM CDs; disabled for playstimulator! (The position of the first BGM CD will be programmed in the next step; ref to sec. 9.4.2)
- B = repeat time between BGM tracks (10 min.)  
 BGM-continuous play = 99  
 BGM OFF = 00

To program press selection button 7 -hold down- and press selection button R. Release both buttons. The display goes dark. Enter the number of CDs and the repeat time by means of the selection buttons.

**9.4.2 Start position for BGM CDs and configuration, level 3 button 8**

Press button 8. The start position of the BGM CDs is displayed in the left two digits. The RH digit indicates the actual BGM mode.

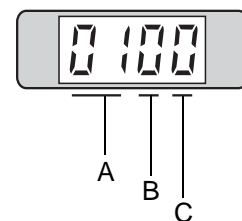

- A = start position of BGM CDs
- B = not used, always 0
- C = BGM mode

You can determine the digit for the BGM mode as follows:

BGM mode	selection
You want to select BGM CDs by coin insertion too:	yes -> 0; no -> 1
You want that the jukebox plays BGM-CDs also if credit still exists:	yes -> 2; no -> 0
BGM start position over 100:	yes -> 4; no -> 0

Select the desired features and add the corresponding code numbers. Enter the sum of the code numbers as the mode digit.

**Example:**

BGM-CDs not selectable by coin insertion	=	1
BGM-CDs should not be played at still existing credits	=	0
BGM start position over 100	=	4
Mode number	=	5

To program press selection button 8 - hold - and press selection button R. The digital display goes dark. Enter start position (2 digits) followed by a '0' and the BGM mode (1 digit)!

After entering this data the SCC unit calculates the BGM end position itself. For loading of BGM discs the end position can be calculated as follows:

$$\text{end position} = \text{start position} + \text{number of BGM-CDs} - 1.$$



**NOTE:** If a wall box is connected the BGM selection option must be set to 0.

**9.4.3 BGM time zones at different weekdays, level 3 button 0 - 6**

You can program each weekday differently with two intervals per day. The following steps are the same for the buttons 1 to 6 in service level 3 according the table for weekdays.

1. Press button 0, the display shows flashing:
  - ⇒ 0 (LH) = Sunday
  - 1 means start time one
  - ⇒ programmed time will be displayed, here 9.00 o'clock
  
2. Press selection button 0 again, the display shows flashing:
  - ⇒ 0 (LH) = Sunday
  - 2 means stop time one
  - ⇒ programmed time will be displayed, here 12.30 o'clock
  
3. Press selection button 0 again, the display shows flashing:
  - ⇒ 0 (LH) = Sunday
  - 3 means start time two
  - ⇒ programmed time will be displayed, here 20.00 o'clock
  
4. Press selection button 0 again, the display shows flashing:
  - ⇒ 0 (LH) = Sunday
  - 4 means stop time two
  - ⇒ programmed time will be displayed, here 23.45 o'clock

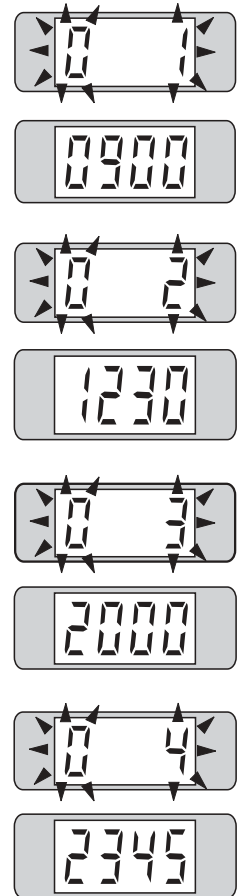

To program press selection button 0 (or button 1 - 6 depending on the weekday to be programmed). The digital display goes dark. Enter the two time zones in four blocks containing four digits per block one after another (16 digits).

Table of weekdays:

0 = Sunday	4 = Thursday
1 = Monday	5 = Friday
2 = Tuesday	6 = Saturday
3 = Wednesday	

**Examples:**

The jukebox should play BGM on Tuesday from 9.30 to 11.45 and from 17.00 to 19.55. To program press selection button 2 - hold - and press selection button R. The digital display goes dark. Then enter 0-9-3-0-1-1-4-5-1-7-0-0-1-9-5-5.

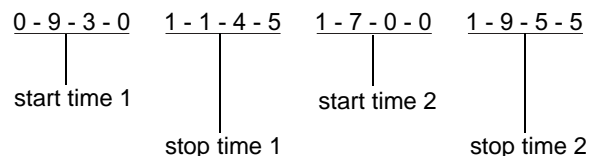

If the jukebox should play BGM on Wednesday from 17.00 to 19.55 only, then program on selection button 3 as described: 1-7-0-0-1-9-5-5-0-0-0-0-0-0-0-0 . The second time zone has to be filled with zeros. Also this programming is possible:

0-0-0-0-0-0-0-0-1-7-0-0-1-9-5-5.

Repeat this procedure until all weekdays are programmed (selection buttons 0 to 6).

## 9.5 Happy hour pricing (additional bonus plays)

During the 'Happy hour' time additional bonus plays can be given. Happy hour time zone and number of additional bonus plays have to be programmed as follows.

### 9.5.1 Programming of the happy hour start and stop time, level 2 button 6

1. Set the slide switch 'service' at the SCC unit to ON.
2. Press 'LT' button. Display shows e.g.: \_ 4 0 9  
⇒ (409 or higher = SCC program version)
3. Press selection button R -hold down- and press selection button 0, then release both buttons. The display is dark.
4. Press selection button 2. Service level 2 is reached. Display shows: 2\_ \_ \_.
5. Press selection button 6. The display shows flashing:  
⇒ 1 means start time  
  
⇒ the start time will be displayed with four digits e.g.: 9.00 o' clock
6. Press selection button 6 again. The display shows flashing:  
⇒ 2 means stop time  
  
⇒ the stop time will be displayed with four digits e.g.: 12.30 o' clock
7. To reprogram press selection button 6 - hold - and press selection button R. The digital display goes dark. Enter the 'Happy hour' start and stop time with 8 digits. After complete entry the digital display is dark.  
⇒ Example: "Happy Hour" should operate from 09.05 to 11.00 o'clock.  
Enter 8 figures: 0 - 9 - 0 - 5 - 1 - 1 - 0 - 0 .
8. To check the settings: Repeat the steps 5 and 6.

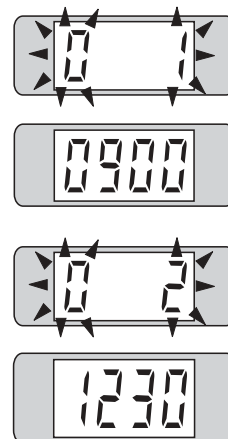

### 9.5.2 Programming of the additional bonus plays, level 2 button 7

1. Press selection button 7. The display shows e.g.:  
⇒ 1 additional play at bonus level 4 (B1)  
⇒ 3 additional plays at bonus level 3 (B2)  
⇒ 5 additional plays at bonus level 2 (B3)  
⇒ 7 additional plays at bonus level 1 (B4)
2. To reprogram press selection button 7 - hold - and press selection button R. The digital display goes dark. Enter the new happy hour pricing with 4 digits.
3. To check the new setting, press selection button 7 again.
4. To exit the service program set the slide switch 'SERVICE' to OFF and press button LT on the SCC unit.

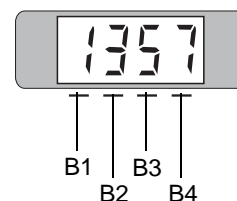

## 9.6 Number of tracks played successively on the same disc, level 2 button 3

The display shows the maximum number of tracks played successively from the same disc. Preset value = 04 tracks, i.e. after four tracks from this CD have been played it will be taken back to the magazine, and the next CD stored in the selection memory will be played. If selections still exist for the previous CD they will be played later. This option to limit the tracks played from one CD is more useful for operators. For individual use this value can be set up to 99.

To call the service program (level 2):

1. Set the slide switch 'service' at the SCC unit to ON.
2. Press 'LT' button. Display shows e.g.: \_ 4 0 9  
⇒ (409 or higher = SCC program version)
3. Press selection button R -hold down- and press selection button 0 than release both buttons. The display is dark.
4. Press selection button 2. Service level 2 is reached. Display shows: 2\_ \_ \_.
5. Press selection button 3 the display shows e.g.: 04 = factory setting for number of tracks played successively on the same disc.
6. To program press selection button 3 - hold - and press selection button R. The digital display goes dark. Enter the desired setting by means of the selection buttons with two digits.



**If you set this value to 01 all selections will be played in selection order.**

7. To check the settings: Press selection button 3 again.
8. To exit the service program set the slide switch 'service' at the SCC unit to OFF and press the 'LT' button once. The changer starts an initialisation run. After this the jukebox is ready to operate.

## 9.7 Disabling single tracks

You can disable up to maximum 25 different tracks of different CD's. If somebody selects a disabled track the digital display flashes. This shows that this track is not selectable. Note a special peculiarity at playstimulator or BGM operation. The random procedure always selects tracks out of a number of 35. If the random selected track exceeds the number of tracks on the CD the procedure starts to count from the beginning of the CD. Result is, if you want to disable e.g. track 8 on a CD with 17 tracks you also have to disable track 23 on this disc although it does not really exist.

To disable tracks (service program level 2):

1. Set the slide switch 'service' at the SCC-unit to ON.
2. Press 'LT' button.
3. Press selection button R -hold down- and press selection button 0 than release both buttons.
4. Press selection button 2. Service level 2 is reached. Display shows: 2\_ \_ \_.

5. Press selection button 4 the display shows e.g.:
  - ⇒ Each operation of selection button 4 indicates the next disabled track, maximum 25 tracks.
  - ⇒ After having reached the last disabled track, the first one is indicated again. If the display shows 0000 after the first button operation no track is disabled.

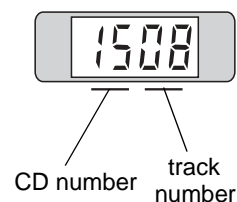

6. To program: Press selection button 4 - hold - and press selection button R. The digital display goes dark
7. Enter at first the CD number to be disabled followed by the track number (total four digits).
8. To disable the next CD/track, press selection button 4 several times until display shows 0 0 0 0 .
9. Press selection button 4 again - hold - and press selection button R. The digital display goes dark. Then enter CD and track to be disabled. Continue programming for the next track to be disabled with step 8.
10. To check the disabled tracks: Press selection button 4 again (up to 25 times, for 25 disabled tracks).
11. To exit the service program set the slide switch 'service' at the SCC unit to OFF and press the LT button.

**To enable a disabled track:**

When a track is indicated, press button 4 - hold - and press selection button R and enter first the number of the CD followed by 0 0.

**To enable all disabled tracks:**

Press selection button 4 -hold down- and press selection button R. Then enter 0 0 0 0 (4 times 0).

**9.8 Location or Identification number, level 1 button 8**

A location or identification number (8 digits) can be programmed.

To enter the number (Service program level 1):

1. Set the slide switch 'service' at the SCC-unit to ON.
2. Press 'LT' button.
3. Press selection button R -hold down- and press selection button 0 than release both buttons.
4. Press selection button 1. Service level 1 is reached. Display shows: 1\_ \_ \_.
5. Press selection button 8, the display shows flashing:
  - ⇒ 1 means higher digits

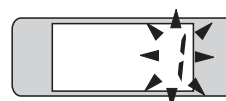

- ⇒ Then the four higher digits will be displayed.



6. Press selection button 8 again, the display shows flashing:
  - ⇒ 2 means lower digits



- ⇒ Then the four lower digits will be displayed.
- ⇒ In this case the number is 8543 1049.



7. To reprogram press selection button 8 - hold - and press selection button R. The digital display goes dark. Then enter the complete number with 8 digits.
8. To check the settings: Press selection button 8 again.
9. To exit the service program set the slide switch 'service' at the SCC unit to OFF and press the LT button.

## 9.9 Album selection and memory reset by power off, level 1 button 9

By setting the corresponding digit these options are available.

Album selection is possible by entering the disc number followed by 0 0 (track 0 0). All tracks on the CD are played, starting with the first track. An album is only selectable by coin insertion, if credits of the 4th bonus level have been obtained or in free play modus (link in row GP from 0 to F on the SCC unit) of the jukebox.

Memory reset feature will cancel remaining credits and selections by power off of the jukebox. This option prevents the jukebox playing preselected tracks from the day before (the jukebox was switched off in the night.).

To change the settings (Service program, level 1):

1. Set the slide switch 'service' at the SCC-unit to ON.
2. Press 'LT' button.
3. Press selection button R -hold down- and press selection button 0 then release both buttons.
4. Press selection button 1. Service level 1 is reached. Display shows: 1\_ \_ \_.
5. Press selection button 9, the display shows e.g.:
  - ⇒ A = digit for memory reset by power off; 1 = ON, 0 = OFF
  - ⇒ B = digit for albumplay; 1 = ON, 0 = OFF
6. To change the settings press selection button 9 - hold - and press selection button R. The digital display goes dark. Enter the desired setting with two digits.
7. To check the settings: Press selection button 9 again.
8. To exit the service program set the slide switch 'service' at the SCC unit to OFF and press the LT button.

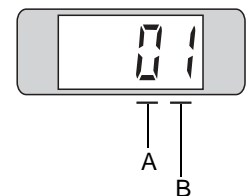

# 10 Data retrieval

The data retrieval memory stores data only if the plug 'MEMORY' is always in the position ON (on the bottom side of the SCC unit).

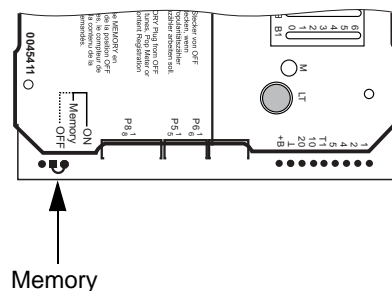

## 10.1 Operator data

You can read out statistical data in the service program level 1 over the display.

1. Set the slide switch 'service' at the SCC-unit to ON.
2. Press 'LT' button.
3. Press selection button R -hold down- and press selection button 0 than release both buttons.
4. Press selection button 1. Service level 1 is reached. Display shows: 1\_ \_ \_.

### 10.1.1 Retrieval of least popular discs (flops), level 1 button 0

1. Press selection button 0 once.
  - ⇒ At first the least played CD is shown. The last two digits are simply a code confirming the least played status. The display shows alternately the disc number and the number of plays e.g.:



- ⇒ If the counter shows 0 0 0 0, this means the disc has not been played. Press selection button 0 to continue the process for the second least played disc, and so on. At first the CD with the lowest number of plays will be displayed. Press button 0 again, the display shows the CD with the second lowest number of plays etc. If the calculation needs a little longer a '1' scrolls starting from RH. digit over the display.

2. To cancel the procedure press selection button R.



**10.1.2 Top Tunes, level 1 button 1**

Press selection button 1 once.

The display shows alternately the number of the most played CD and the number of plays. For example:



Only 63 selections per CD can be stored in the memory. If a CD has been played more than 63 times all the other values will be decreased by 1. The displayed values are only relative.

Press selection button 1 to continue the process for the second most played CD, and so on.

The most frequently played track will also be displayed as HIT OF THE HOUSE in normal operating mode.

**10.1.3 Cash box contents, level 1 button 2**

1. Press selection button 2 once. Digital display shows the cash box contents in basic units; basic units being the value of the lowest coin.
2. To cancel the procedure press selection button R.

**10.1.4 Total number of plays, level 1 button 3**

1. Press selection button 3 once. Display shows the total number of plays since last reset (maximum 9999).
2. To cancel the procedure press selection button R.

**10.1.5 CLEAR ALL counters (reset to 0 0 0 0), level 1 button 3 + reset**

1. Press selection button 3 - hold - and press selection button R (reset).
  - ⇒ The counters belonging to the buttons 0 to 3 (least popular disc, most popular disc, cash box and total plays) are cleared and reset to 0 0 0 0.
  - ⇒ After leaving the service program the jukebox initializes itself, during this procedure the compartments in the magazines will be counted. At the end of the initialization the display should show 6161 for a short time. If lower numbers are displayed not all compartments have been detected correctly. The sequence of top discs is for the time being 01, 02, 03, 04 etc.

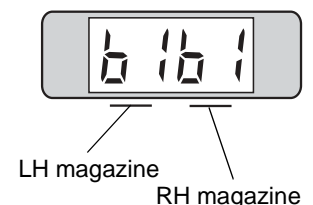

2. To exit the service program first set service switch to OFF and then press the LT button.

**10.1.6 Memory of not playable CDs, level 1 button 6**

Careful handling of the CDs does not completely exclude that CDs may be damaged in different ways. Possibly the player would interrupt this CD at each selection. The SCC provides a watch dog function which finds and memorizes these difficulties to play.

The SCC unit can store the numbers of up to six not playable CDs. Once a CD is registered every new try will be counted. So it is possible to find out defective discs and exchange these for new ones.

1. Press selection button 6, the display shows flashing:

⇒ 1 means first defective CD

then e.g.

⇒ A = CD number

⇒ B = NUMBER of times the CD was not playable or interrupted

2. Press selection button 6 to display the next not playable CD, etc. After displaying the 6th not playable CD and pressing selection button 6 again the display starts with the first one again.
3. To CLEAR this memory press selection button 6 - hold - and press selection button R.
4. To exit the service program, first set service switch to OFF and then press LT button.

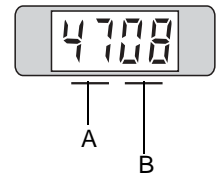
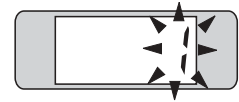

# 11 Amplifier F91

The amplifier F91 is the version with higher power output (2 x 170 W rms.). Equipped with protection and watch dog functions described below. The BGM adapter (to attenuate the volume in BGM mode) is integrated. The amplifier is equipped with an automatic volume control (AVC) to level out different recording levels.

In 2-channel mode it is possible to control both channels separately with the IR-remote control.

You can also make selections with the optional infrared remote control.

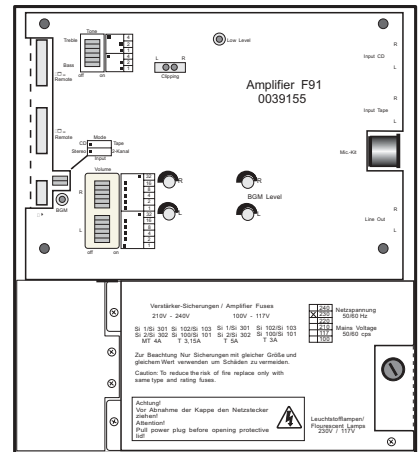

## 11.1 Verification of power voltage



**ATTENTION!** Always remove power plug before opening transformer cover plate. Never attempt any intervention to these parts unless qualified.

The power voltage setting is on the cover plate of the F91 transformer. Machines for USA are set to 117 V. Jukeboxes „UNI-Pack“ are shipped in 230 V setting. This is marked on the machine label inside of the door. If the voltage setting is not clear the transformer cover plate has to be removed.

The mains fuse (T3,15 A, res. T8 A for 117V) is located near the RH side of the cover plate.

The position of the two plug connectors on the transformer terminals 1 to 9 (primary side) indicates the current voltage setting. The following combinations are possible:

- 240V = 1 - 9
- 230V = 1 - 8
- 220V = 2 - 9
- 210V = 2 - 8
- 117V = 1 - 6
- 100V = 2 - 6

**Never connect the fluorescent supply to other contacts.**

If you intend to change the power voltage to a higher voltage (e.g. from 117V to 230V) it is recommended to use a subtransformer for the fluorescent lamps or change the ballast according to the used voltage (e.g. for 230V).

The power consumption in standby is approx. 146W. With max. volume it is approx. 540W.

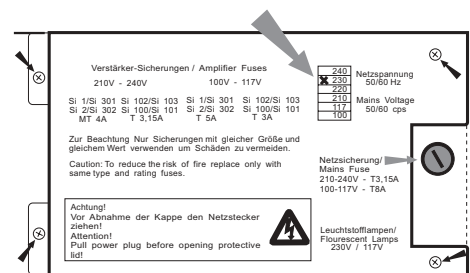

Loosen the 4 screws to remove cover plate (small arrows)

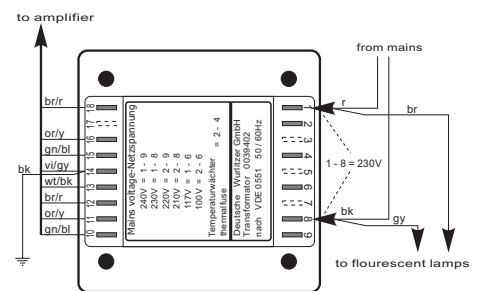

## 11.2 Position of fuses and plug connectors on the power amp board



**WARNING!** A voltage of approx. +60V res. - 60V applies to the fuse terminals also a certain time after power off. Change the fuses with caution !

Usually the jukeboxes are fitted with fuses of DIN 41571 (5x20 mm) slow blow or medium blow. Slow blow fuses of DIN standard bear the letter T (T = "Träge") e.g. T 4/250 means T = slow blow, 4 amps, 250 V maximum operating voltage. Which fuses have to be used is printed on the power transformer cover. Fast blow fuses (F = Flink) are unsuitable for the jukebox.

The fuse holders on the amplifier P.C.B. are capable to hold also fuses of 6x32 mm size.

### Position of the plug connectors

P12 - jukebox speakers

P 3 - bubble tubes

P16 - power transformer

P 4 - CD sub transformer, CD player

P 9 - mechanism, Selection and Credit Computer

P 6 - option, coin interface

P6A - option

P 7 - service

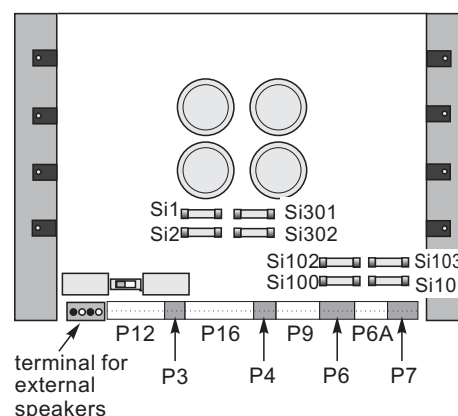

### Fuse

Main fuse T 3,15, res. T8 A for 110/117 V.

Fuse Si1: T4A (T5A) +70V= L.H. channel power stage

Fuse Si2: T4A (T5A) -70V= L.H. channel power stage

Fuse Si301: T4A (T5A) +70V= R.H. ch. power stage

Fuse Si302: T4A (T5A) -70V= R.H. ch. power stage

Fuse Si100: T3,15A (T3A) supply -30 V=

Fuse Si101: T3,15A (T3A) supply +30 V=

Fuse Si102: T3,15A (T3A) supply +12 V=

Fuse Si103: T3,15A (T3A) supply 30V ~

### Failure

No illumination, machine completely dead.

No sound in the L.H. channel. Speaker relay is not activated, green LED does not light.

No sound in the R.H. channel. Speaker relay is not activated, green LED does not light.

The jukebox operates normal. The CD2 mechanism does not use this voltage.

No initialisation run after power ON. Display working. No function.

SCC unit dead - digital display dark (except red LED M still lighting up on coin insertion).

The LEDs K and Z on the SCC unit are dark. No initialisation run after power ON.

The digital digit on the CD-control is dark. Power supply for CD player and control unit is interrupted. Credit circuit via LED M is interrupted. If credits are still in memory or free play is programmed, a CD will be placed on turntable but is not spinning. After about one minute the CD is taken back..

If no credits in memory, no CD will be taken to turntable, the display is flashing.

### 11.3 The first power ON

The mains switch is located at the bottom left hand rear side of the jukebox. In position 'I' jukebox and amplifier are switched on. The amplifier is now in STANDBY MODE:

The yellow 'Low Level LED' lights.

The 'Low Level' circuit detects low music parts and pauses. It effects the AVC circuit not to raise the audio level in music pauses. So disturbing noises will not be heard. This LED may light for short times during play.

The yellow 'Mute LED' lights (on the power amp board, only visible after lifting up the pre amp board). It indicates that the amplifier is muted.

To avoid power on and other noises, the amplifier output will be switched on only during play.

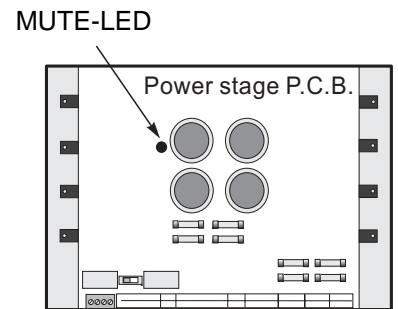
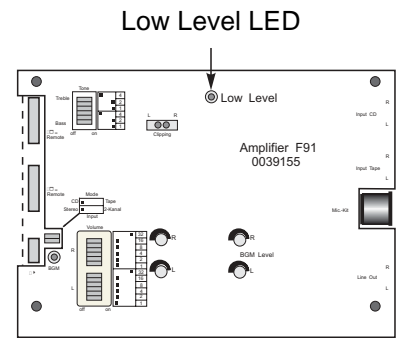

### 11.4 Pre-settings for volume, bass, treble

After power on of the jukebox or after pressing the button 'preset' the levels of volume, bass and treble will be set to basic values. These values can be set with different binary DIP switch combinations. The switches are located on the amplifier pre amp board. You can find the recommended settings on the amplifier cover.

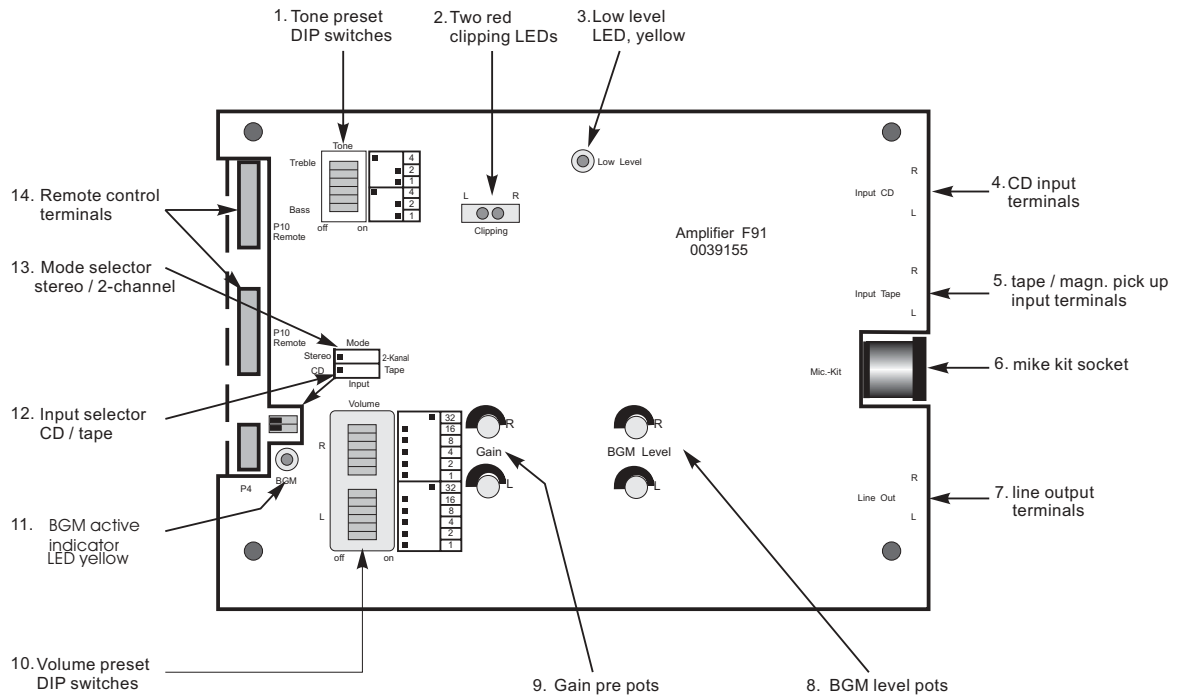

### 11.4.1 Pre-settings for volume

You can set the basic values for volume in 63 steps (to 2dB) from no up to maximum volume.

On the amplifier front cover you can find 6 DIP-switches (preset value) for each channel. These switches have different values (1, 2 ... to 32). If you add all the values of the switches in position "ON" you will get the value for the preset volume.

The recommended factory settings are printed on the amplifier cover (32).

If you change the DIP-switch settings while the juke-box is operating, new settings will be taken over after having pressed the button 'PRESET' at the control terminal or on IR remote or after power on.

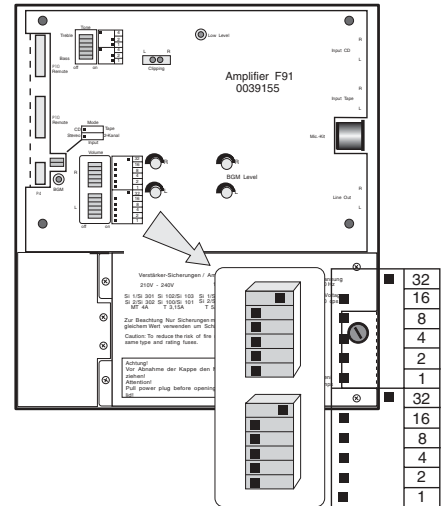

DIP switches for volume pre-settings



**WARNING!** If all switches are in position OFF no volume, if all switches are in position ON, the maximum volume appears at power on !

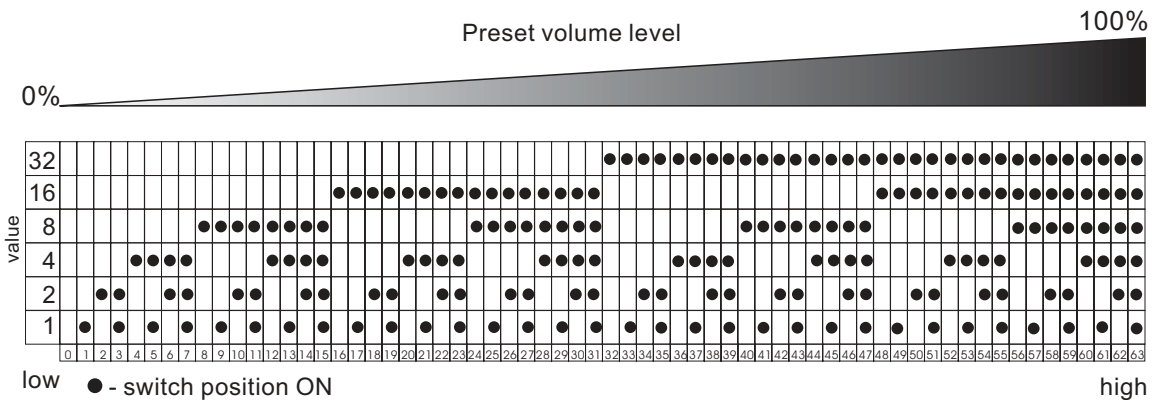

### 11.4.2 Pre-settings for bass and treble

Like wise the values for bass and treble can be set. However for both channels together.

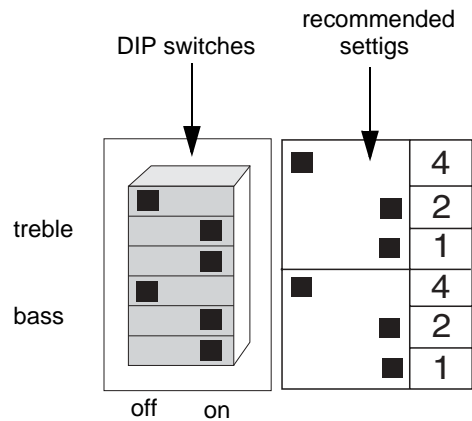

Three DIP-switches with the values 1, 2, 4 are provided for each bass and treble. You can choose 7 different steps of 3dB from minimum (-9dB) to maximum (+12dB). Adding value of all switches set to "ON" gets the total value.

The 0dB - 'linear' position of these switches is printed as recommended factory setting on the amplifier cover.



**NOTE:** If you change the DIP-switch settings while the jukebox operates, new settings will be taken over after having pressed the button 'PRESET' at the control terminal or after a power off and on of the box.

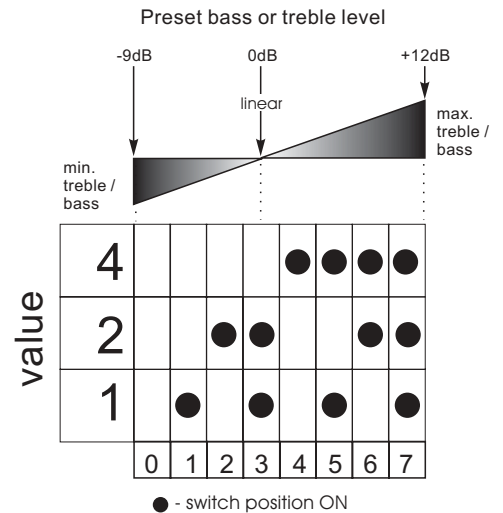

### 11.5 Speaker connections

The speaker connector terminals are situated inside and on the back side of the jukebox.

To attain a good sound of the jukebox, take care when connecting the speakers. Pay attention to the following requirements:

The minimum impedance is 4Ω per channel!

The power output of each channel at a load of 4Ω is 170 W rms, i.e. the min. power consumption of a 4Ω speaker set should be 200 Watts.

All speakers must be connected with the correct polarity.

The speakers may be operated as desired in the mode STEREO or 2-CHANNEL .

In STEREO mode the sound reproduction is always stereo.

In 2-CHANNEL mode it is possible to control the volume of both channels independent to each other. It allows to reproduce the sound in a second room with different volume. The sound reproduction in this mode is only mono.

In 2-CHANNEL mode the volume of the speakers connected to the normal terminals (R.H. channel) can be controlled with the mode 'VOLUME' and the volume of speakers connected to the screwing terminals on the amplifier (LH channel) with the mode 'BALANCE'. The preset volume can be set separately.

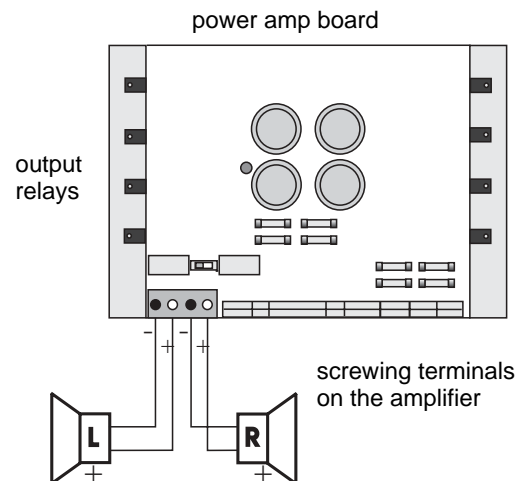
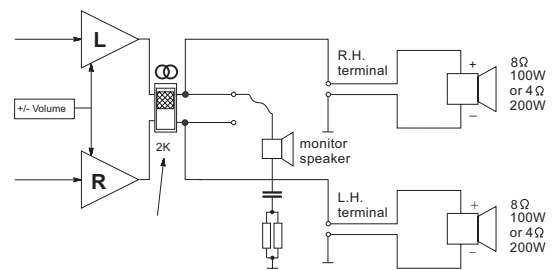

**11.5.1 The operating mode STEREO**

For normal operation the jukebox is set to the STEREO mode. Both amplifier switches, the mode switch and the slide switch S1 on the power amplifier board are set to position STEREO.

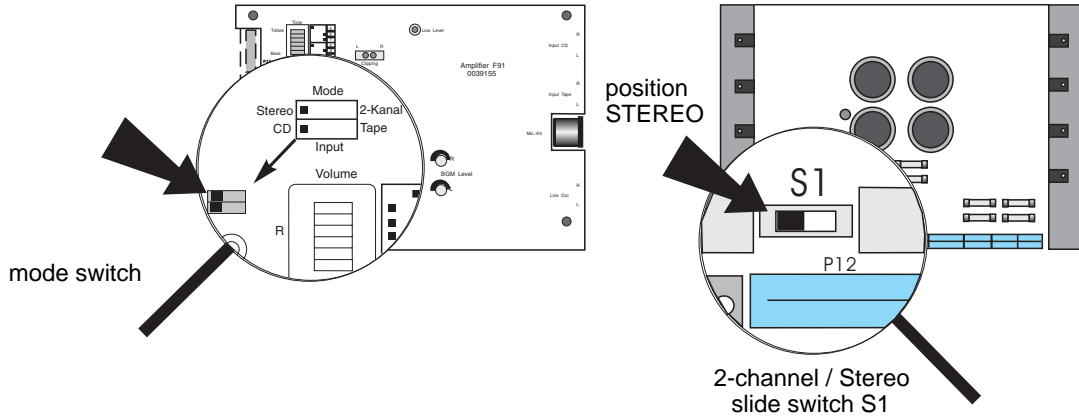

**Example 1:**

Two 8Ω speaker connected in parallel per channel

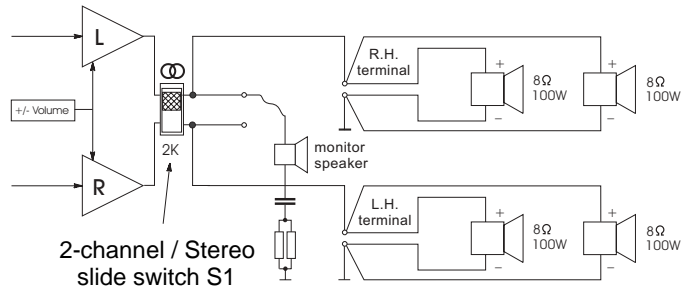

**Example 2:**

2 times 4 Ω speaker connected in series and in parallel with one 8Ω speaker

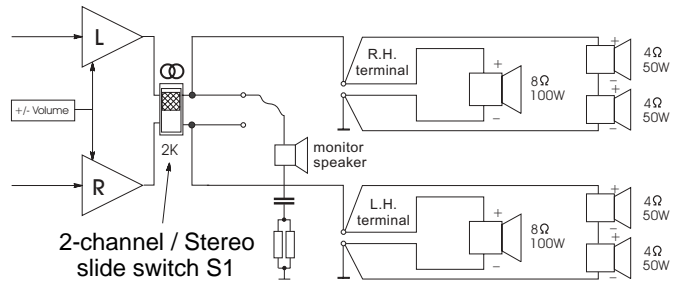



## 11.6 Connecting external speakers in operating mode 2-CHANNEL

For 2-CHANNEL operation both amplifier switches, the mode switch and the slide switch S1 on the power amplifier board are set to position 2-CHANNEL.

As the following examples show, in the 2-CHANNEL mode it is possible to connect different loads to each amplifier output. Take care that the min. impedance is 4Ω per channel.

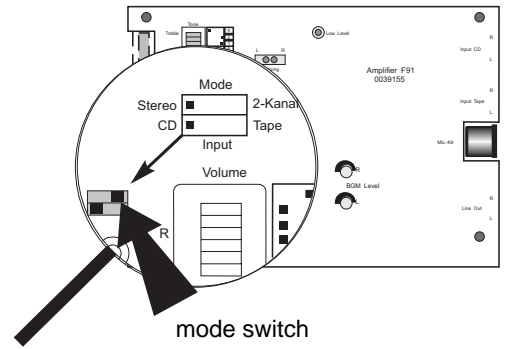

mode switch

2-channel / stereo slide switch S1 in position 2-channel

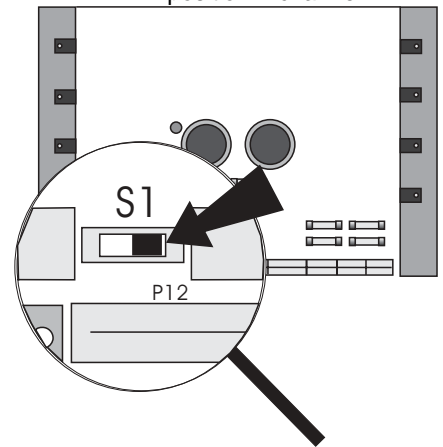

### Example 1:

1st room a speaker of 4Ω 200W, 2nd room 4speaker of 2Ω 30W connected in series

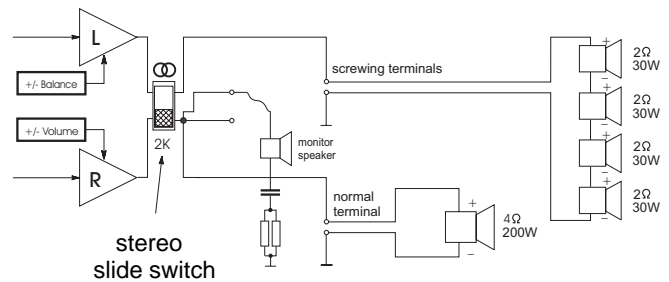

### Example 2:

1st room a speaker of 4Ω 200W, 2nd room 4speaker of 16Ω 50W connected in parallel

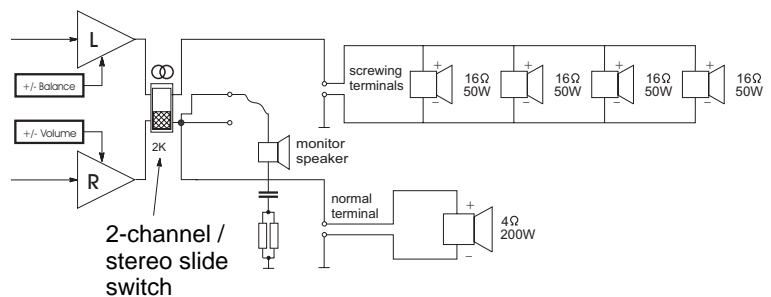

### 11.7 BGM mode - volume attenuation

In the BGM (**B**ack**G**round **M**usic) mode the volume will be reduced by a certain factor.

This function is controlled by the signal „BGM“ pin 1 plug brown from the SCC unit. The active BGM mode is displayed with a yellow LED near plug P4. In this mode the volume of the normal sound is adjustable by two BGM trim pots in the center of the pre-amplifier board.

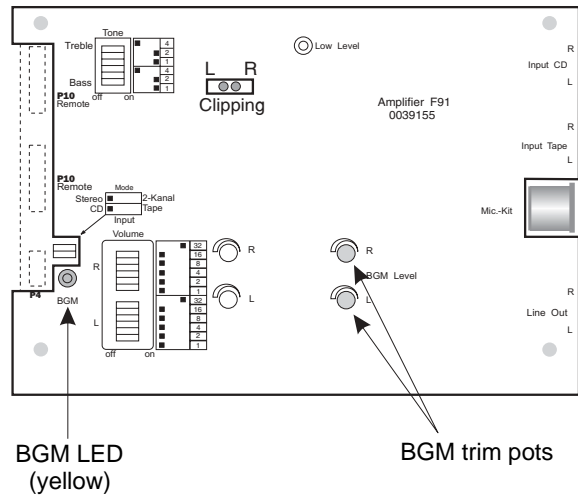

### 11.8 Automatic volume control (AVC) and clipping stage

The AVC sets CDs with different volume levels to an equal level. The level of CDs with a high level will be reduced, the level of low leveled CDs will be increased. This control works rather slow to save the dynamic range of the track.

The pre amp gain pots are situated between the volume pre-set switches and the BGM level trim pots. These two pots are factory pre set should **not** be adjusted.

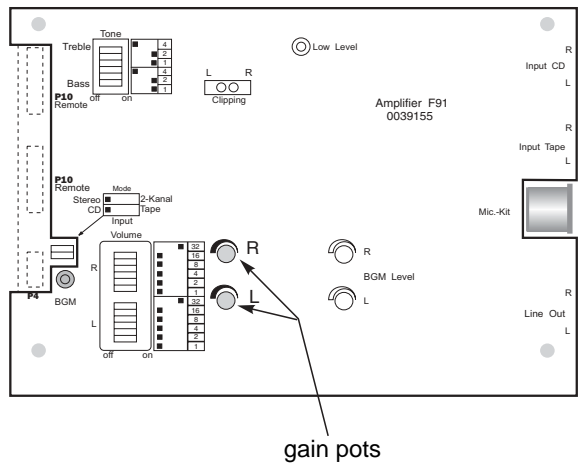

### 11.9 Overdrive protection

In case of an overdriven power amp one or both red clipping LEDs will light. The clipping circuit will have an effect on the AVC circuit and the volume will be reduced. Occasional lightning of the clipping LEDs during a loud performance is normal. Continuously lightning of one or both LEDs indicates an overdriven channel and distortion can be heard. It is recommended to reduce the volume.

Also speakers with an impedance lower than 4Ω (in STEREO mode) may cause an overload and the LEDs will light.

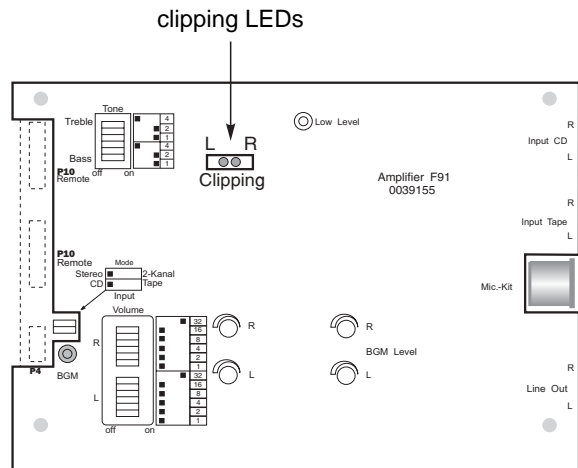

### 11.10 Overload protection

The power amplifier is provided with an overload protection circuit.

While the CD is playing two green LEDs indicate that the speaker output relays are activated. If one of these LEDs is dark during play and no sound appears an overload of the power amp stage has occurred, which is for example caused by a short circuit in the connection wires to the external speakers.

An additional internal watch dog circuit checks that the audio signal contains no DC Voltages and no high sublow frequencies. It also indicates that the load limitation cut off has been reached. If only one test is not successful the relays will be switched off.

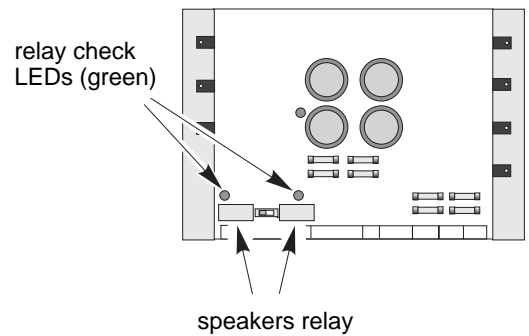

### 11.11 Tape input

Additional to the CD input a tape input with a higher input sensitivity is provided. As an option this input stage may be wired as a correcting network to work with a magnetic pick up (RIAA). Set the 'input' DIP switch to tape position to select the tape input.

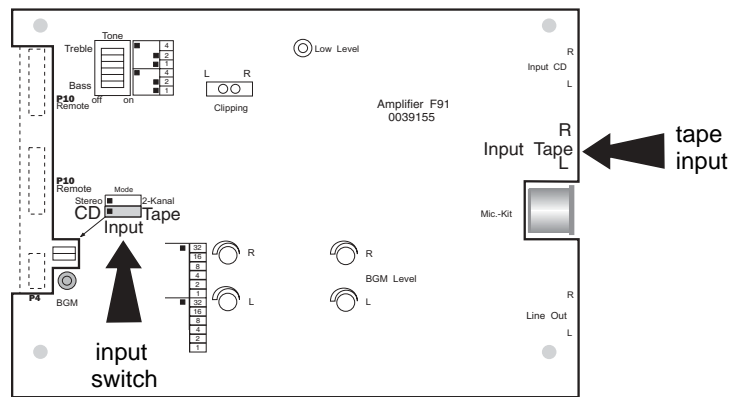

## 12 Amplifier K99

### 12.1 Device description of the amplifier K99

The amplifier K99 is optimised for universal use in Deutsche Wurlitzer GmbH music machines. Great importance had been attached for an easy handling and stand alone function without the S&CC unit. The output power is designed for the typical used internal speakers at Deutsche Wurlitzer GmbH machines, under normal circumstances reaching an impeccable volume level.

#### Standard equipment:

- Hybrid power stage technology, short circuit and over temperature protected
- 2 inputs (stereo): CD and tape
- 1 mono input for optional micro kit
- Volume control with 2 pots onboard
- Volume control possible with pots and / or IR at the same time. The pot used at last determines the volume.
- Bass and treble control with pots
- BGM volume reduction, controllable with pot
- Automatic volume correction (AVC), switchable
- 2 channel operation switchable, RH = internal speakers, LH = external speakers
- Status display with 7segment display
- Independent controllable RCA output to connect external amplifiers
- For use with the old and the new changer mechanism.

#### Optional:

- Remote control of F91 with large distance range. Functions: track selection / volume chan. 1 / volume chan. 2 / mute (toggle) / cancel
- Volume control with two pots in the wired remote box accessible from the machine rear wall, or external. Cancel button and mute button (with toggle function).
- Output transformer (like F91)
- Microphone kit

### 12.2 Technical data

	General	USA / Canada
Supply	100v - 240v	117v
Mains frequency	50cps - 60cps	60cps
Input voltage CD	typ. 1.2v	typ. 1.2v
Input voltage tape	300mv	300mv
Output voltage pre amplifier	<=1veff	<=1veff
Output power	2 x 55w (rms)	2 x 55w (rms)
Output impedance	min. 4ohm	min. 4ohm
Transmission range	20cps - 20,000cps	20cps - 20,000cps
Distorsion factor	< 1%	< 1%
Noise level	depending on the adjusted volume of the jukebox loudness levels of more than 70 dB(A) can be reached.	

### 12.3 Verification of power voltage

The voltage settings are marked on the cover plate of the mains transformer. Machines for USA are set to 117V. They have a special transformer according to UL standard which is not adjustable. Jukeboxes "UNI-Pack" are shipped in 230V setting. This is marked on the machine label inside of the door. If the voltage setting is not clear the transformer cover plate has to be removed. The mains fuse (T3.15A) is located on the left bottom side inbetween the three terminals for the bill acceptor, the external mains switch and the fluorescent lamps.

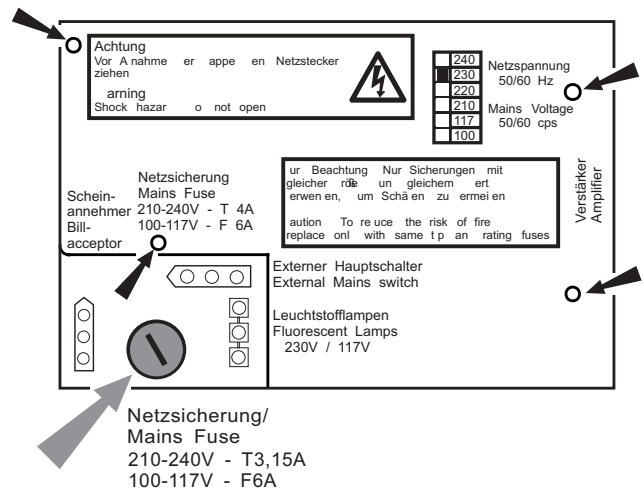

Loosen the four screws to remove the cover plate (small arrows).



**ATTENTION!** Always remove power plug before opening transformer cover plate. Never attempt any intervention to these parts unless qualified!

The position of the two plug connectors on the transformer terminals 1 to 9 (primary side) indicates the current voltage setting. The following combinations are possible:

- 240V = 1 - 9
- 230V = 1 - 8
- 220V = 2 - 9
- 210V = 2 - 8
- 117V = 1 - 6
- 100V = 2 - 6

Notice that these settings cannot be made on machines produced according to UL standard.



**NOTE:** Never connect the fluorescent supply to other contact.

If you intend to change the power voltage for a higher voltage (e.g. from 117V to 230V) it is better to use a subtransformer for the fluorescent lamps or change the ballast according to the used voltage (e.g. for 230V).

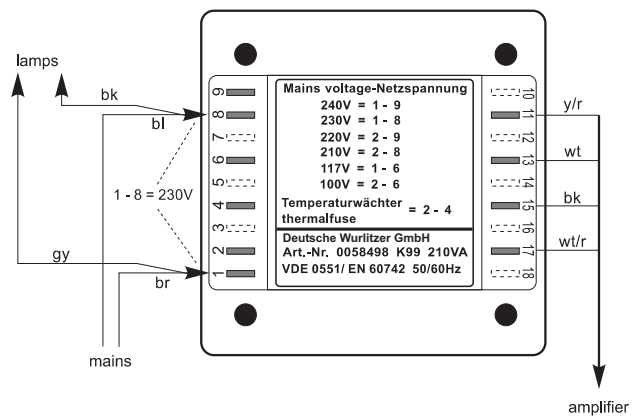

## 12.4 Position of fuses and plug connectors

Usually the jukeboxes are fitted with fuses of DIN 41571 (5x20 mm) slow blow or medium blow. Slow blow fuses of DIN standard bear the letter T (T = "Träge") e.g. T 4/250 means T = slow blow, 4 amps, 250 V maximum operating voltage. Which fuses have to fit in is printed on the power transformer cover. Fast blow fuses (F = Flink) are unsuitable for the jukebox.

The fuse holders on the amplifier P.C.B. are also capable to hold fuses of 6x32 mm size.

You will find the fuses behind the amplifier cover plate. To remove the plate first unplug the cable coming from the mains transformer. Next lose slightly both nuts on top of the amplifier accessible through the holes in the cover plate (arrows). To remove the plate first take the bottom side out of its hinges and then the top side.

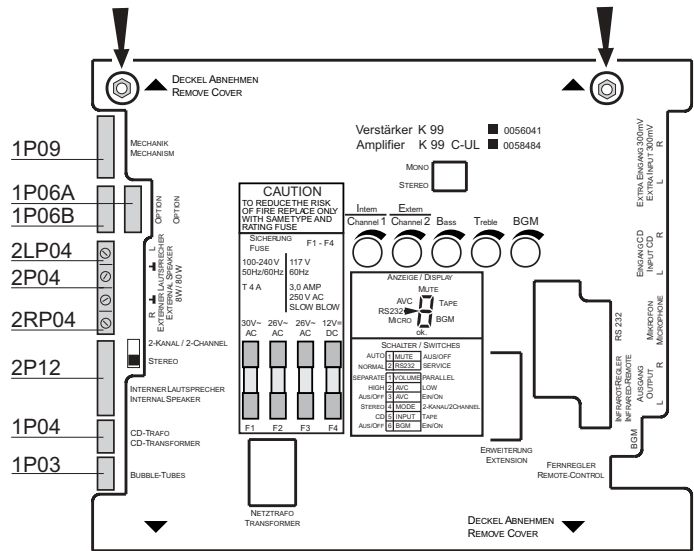

### Connection plan of the plug terminals:

- 1P09 - mechanism, SCC unit
- 1P06A - option
- 1P06B - option
- 2LP04 - external speakers, LH
- 2P04 - external speakers, ground
- 2RP04 - external speakers, RH
- 2P12 - Internal speakers
- 1P04 - CD sub transformer, CD player
- 1P03 - bubble tubes

### Fuse

Main fuse T 3,15, res. F6 A for 110/117 V.

Fuse F1: T4A supply 30V ~

Fuse F2: T4A supply 26V ~

Fuse F3: T4A supply 26V ~

Fuse F4: T4A supply +12 V=

### Failure

No illumination, machine completely dead.

The digital digit on the CD-control is dark. Power supply for CD player and control unit is interrupted. Credit circuit via LED M is interrupted. If credits are still in memory or free play is programmed; a CD will be placed on turntable but is not spinning.

The colour tubes of the One More Time do not rotate, the heating of the bubble tubes is off - no bubbles will appear. Possibly defect of the power stage of the amplifier.

SCC unit dead - digital display dark (except red LED M still lighting up on coin insertion). The LEDs K and Z on the SCC unit are dark. No initialisations run after power ON. The status display on the amplifier is dark.

## 12.5 The first power ON

The mains switch is located at the rear side of the amplifier and thus it is on the rear side of the jukebox. For wall-boxes it is possible to connect an external mains switch to the amplifier accessible then from the side. In position 'I' jukebox and amplifier are switched on.

Up to approx. 1 sec. after power on random segments of the status display will light. Followed by displaying the version number of the amplifier software (1.0 or higher). Then the bottom segment for "ok." and the upper segment for MUTE will light. The amplifier is now in STANDBY MODE. Depending on other enabled options more segments may light as well (e.g. AVC).

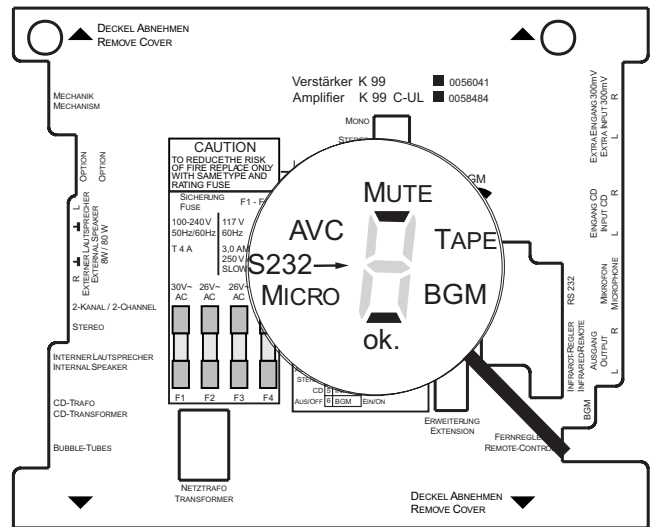

## 12.6 Volume control

You can control the volume of the jukebox from different points at the same time:

- With the pots Vol. 1 and Vol. 2 on the amplifier.
- With an optional connectable IR remote control.
- With the pots of the control box at the rear side of the jukebox.

The device from which the volume is changed determines it.

The volume control unit can be taken out and may be mounted at another place as a remote control. Its cable may be extended as required with any kind of wire. The voltages of the control wires are 5V DC.

The control box has two volume knobs (Intern / Channel 1 and Extern / Channel 2). In position "Stereo" the knob "Intern / Channel 1" is effective for the internal speakers. The knob Extern / Channel 2 is controlling the volume of the RCA outputs for an optional external amplifier. In DIP switch position "2 Channel" the channels 1 (RH) and 2 (LH) are controlled separately.



**ATTENTION!** The pots Vol. 1 and Vol. 2 on the amplifier are not effective if the wire control box is connected.

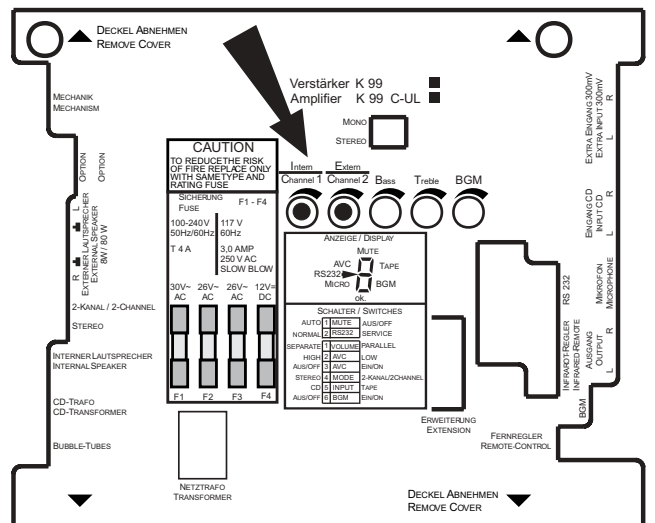

## 12.7 The infrared remote control

As desired an infrared remote control will be installed from factory or can be delivered as conversion kit (part no. 0058809). If it has been installed the hand transmitter is located in the cashbox.

If credit is given or free play is programmed a CD can be selected with the buttons 0 to 9 and R.

Double button functions as required in the service programs (i.e. press button 5 -hold down- and press button R), are impossible. For this you only can use the keyboard of the jukebox.

You can control the volume by means of the buttons + and -. In stereo mode the internal +/- buttons control the volume of the internal speakers. The external +/- buttons control the volume of the K99 RCA jacks for an optional external amplifier. In 2-channel mode you can control the external speakers by the buttons + and - of the external channel.

Beam the jukebox directly if possible.

You can connect the wire remote control box as well.

The power-on volume level is always set by the channel 1 and 2 pots on the amplifier or on the control box (if connected).

Batteries will be delivered. Necessary are 4 micro cells type LR03 (AAA).

To open the battery compartment move the cover like shown in the picture.

Needed battery type and position of the batteries in the hand transmitter are shown on the casing.

Part no. of the hand transmitter: 0059745.

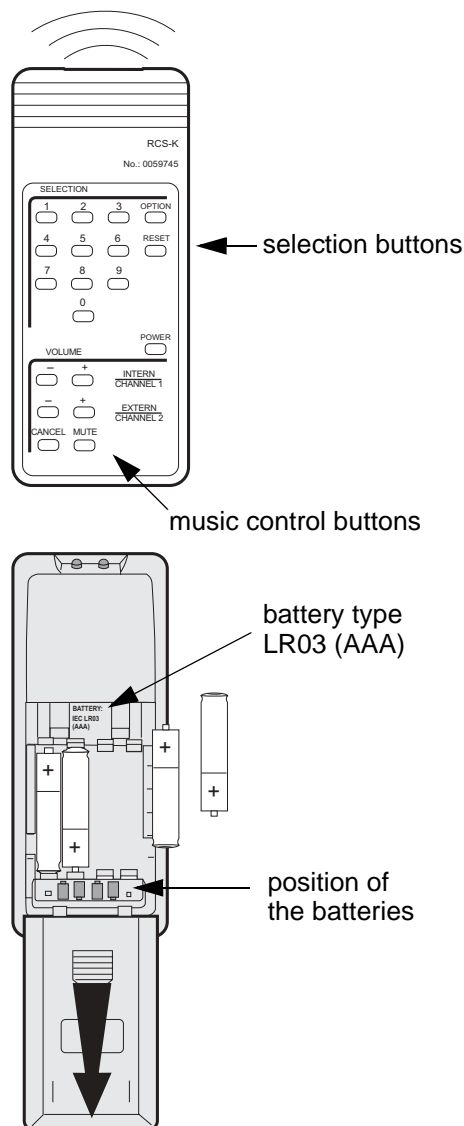



## 12.8 Treble and bass control

You can control the sound with the knobs bass and treble on the amplifier.

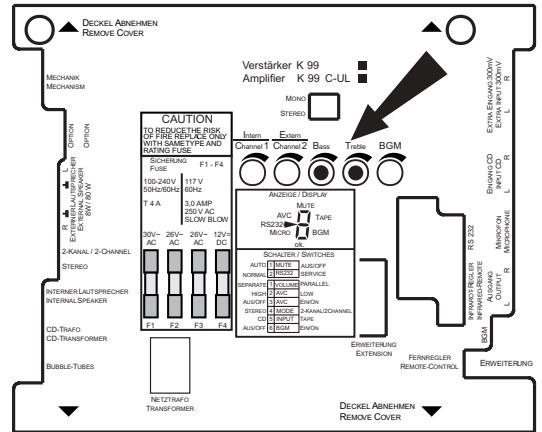

## 12.9 Automatic volume correction

The AVC sets CDs with different volume levels to an equal level. The level of CDs with a high level will be reduced; the level of low-levelled CDs will be increased. This control works rather slow to save the dynamic range of the track.

You can enable the correction with the DIP switch "AVC" (the 3rd switch of the 6 sw. group). Default is AVC disabled.

With the second DIP switch of the 6 sw. group you can reduce the intensity of the volume correction.

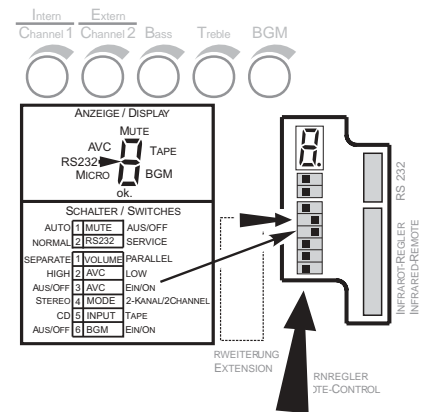

## 12.10 Background Music - volume attenuation

In the BGM (Back Ground Music) mode the reproduction volume will be reduced by a certain factor.

The signal "BGM" pin 1 plug brown of the SCC unit controls this function. You also can switch on "BGM" by means of the DIP switch "BGM" for test purposes. The RH bottom segment of the status display on the amplifier indicates "BGM active". You can adjust the volume attenuation with the pot "BGM", as long as it is active.

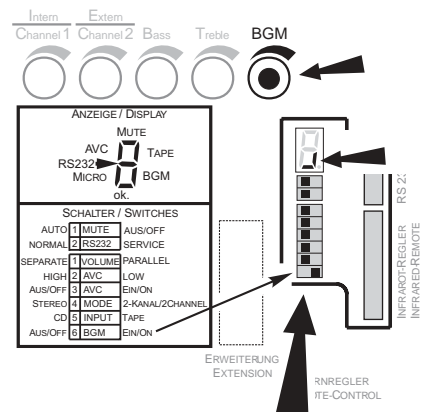

## 12.11 External speaker connection

The amplifier can operate in two different modes. The normal operation mode reproduces the music in normal stereo sound. So external speakers can be added to each channel.

The so-called 2-Channel mode uses both stereo channels like separate mono amplifiers so that the sound can be reproduced in different rooms but then in mono only.

The amplifier may not be loaded with more than 4 ohms per channel (less ohms means more load!). On an overload it switches itself off. After a certain cool down time it switches itself on. So if you do not eliminate the reason for the overload the amplifier produces continuously volume drop-outs.

The impedance of all external speakers per channel in "Stereo" mode should not be less than 4 ohms.

The amplifier applies approx. 55 watts (rms on max. 1% dist.) on a 4 ohms speaker per channel, 18 watts to a 12 ohms speaker and approx. 9 watts to a 24 ohms speaker. That means, that e.g., a 12 ohms speaker connected to the external channel at Dual Channel operation must be a type of at least 18 Watts, otherwise the speaker is in danger of destruction at higher volumes. Note that speaker groups like in hi-fi boxes may have, at certain frequencies, impedance much lower than their rating. Make sure that all speakers are connected in correct polarity.

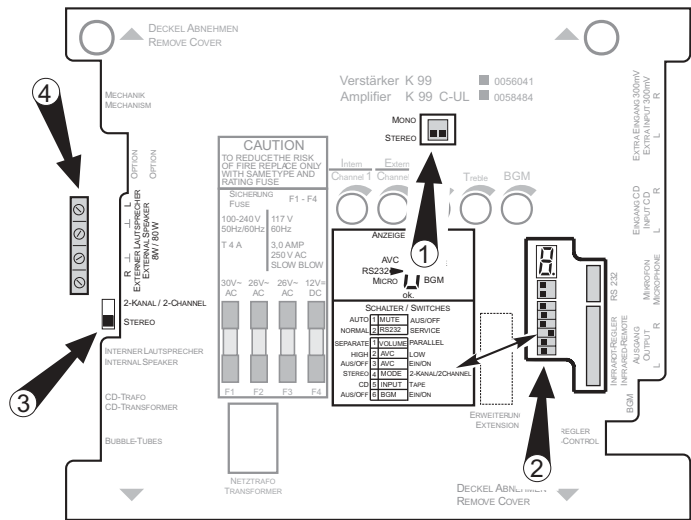

Position of the Stereo - Mono DIP switch (1), the mode switch in the 6 sw.group (2), the stereo - 2 channel switch (3) and the external speaker terminals (4).

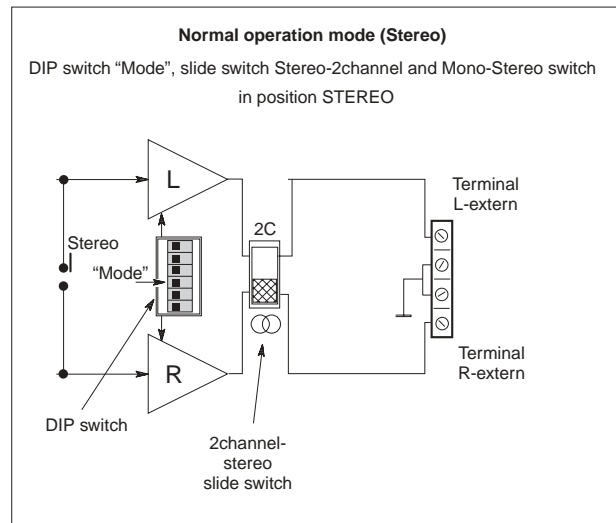



**NOTE:** Connect external speakers to the screw terminals on the LH amplifier side.

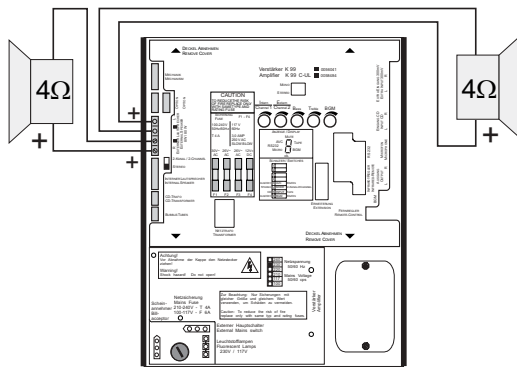

In Stereo mode do not connect a single speaker with less than 4ohm to each channel.

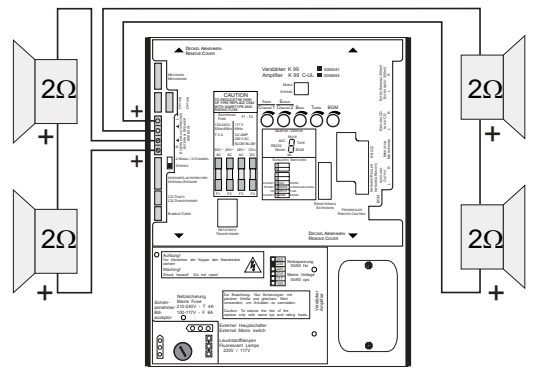

Two speakers of 2ohm also represent total impedance of 4ohm.

## 12.12 External amplifier connection

On the RCA terminals “Ausgang - Output” you can connect an external amplifier with any power rate. In Stereo mode the output level is normally controlled by means of the pot for the 2nd channel. Alternatively you can set the first DIP switch of the 6 sw. group to ON to couple this output to the normal volume control knobs (1st channel), so that both amplifiers can be controlled together.

Connecting an external amplifier in 2-channel mode is not useful.

To avoid hum- (earth-) loops try to use an external amplifier with ground insulation; it has no earth contacts. If it is impossible (e.g. receivers with cable supply) you can separate both amps by means of the ground isolator part no. 0053300.

The signal of the RCA terminals is also controlled by the settings of bass, treble, BGM, AVC and Mute.

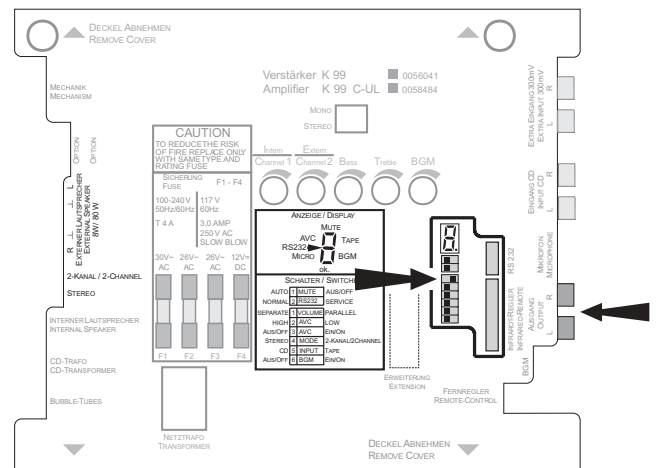

### 12.13 Disabling the internal mute circuit

With the optional BGM-Connector (part no. 0048133) you can connect an external source to the jukebox. In this case the amplifier should not be muted during standby of the jukebox.

Please switch off the internal mute circuit by setting the first DIP switch of the 2 sw. group "Mute" to OFF.

For more information order the Deutsche Wurlitzer GmbH technical information leaflets TI-MA-116 (for F91).

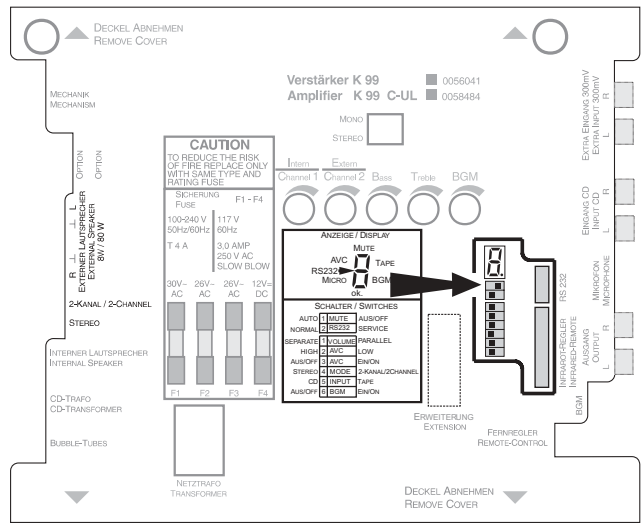

### 12.14 Input selector

With the 5th DIP switch of the 6 sw. group you can set either CD or tape input as active.

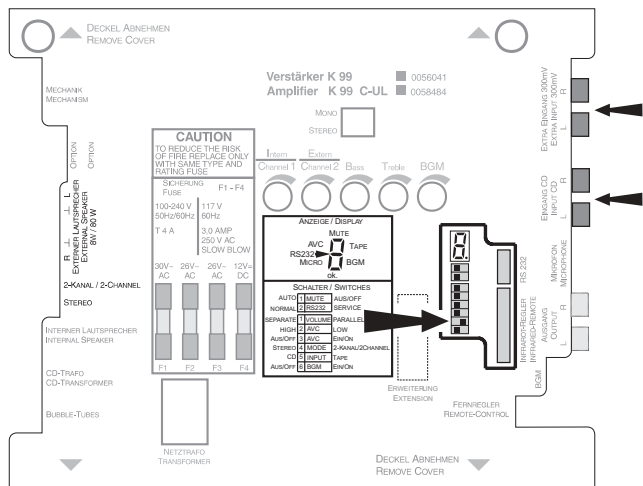

## 13 70v output transformer (0043157)

If you want to work with different speakers with any other impedances or with 70V systems, we recommend to use the output transformer. You can then connect speakers between 2Ω and 16Ω together but complete independent to each other.

If you want to connect several speakers by means of an output transformer pay attention to the following hints:

1. To avoid an interruption of all speakers by the overload protection circuit or a decrease of volume by the clipping stage, the total power outlet of the amplifier should not be exceeded.
2. All speakers must be connected with the correct polarity.
3. To operate each external speaker with the desired volume level, pay attention to the respective efficiency, impedance and load limit.
4. To avoid cable losses on long speaker lines (more than 60 feet) and low impedance, 70Volt-systems should be used as much as possible.
5. If speakers with low impedance (2Ω, 4Ω) are used, each speaker should have its own line with sufficient cross-section.
6. When an output transformer is used no speakers should be connected to the screwing terminals on the power amplifier board P4A.
7. Note: The 2-channel option can not be used in connection with an output transformer without modifying the pre-amp board.

The internal speakers can be operated with lower volume (switches on the connecting board). In position HIGH power consumption of the internal speakers is approx. 32W, in position LOW approx. 10W.

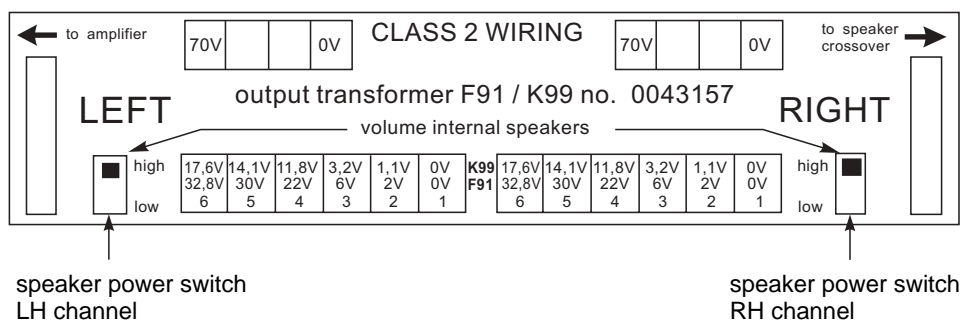

### 13.1 Hints of connectable speaker loads

The maximum power output per channel is 170 Watts (rms) for F91 and 55 Watts (rms) for K99. The power consumption of the connected speakers can be higher (i.e. 200 W) than the maximum remaining power outlet of the amplifier. If the power consumption is lower (i.e. 10 W) than the maximum remaining power outlet of the amplifier, it can be adapted by means of the output transformer.

### 13.2 Determination of the connectable speaker power

The real power consumption of a speaker equals the square of the voltage applied to the speaker terminals divided through the speaker impedance ( $P = U^2 / R$ ). The power values calculated in this way are shown in the following table. The volume level really delivered depends also on the speaker sensitivity and varies from type to type, but it is possible to level out these differences in certain limits.

### 13.3 Hints for speaker connection

- How much amplifier output will be used for the additional speakers, high or low.
  - 140W (F91) / 45W (K99) are available, if the speaker power switch is in position LOW.
  - 70W (F91) / 23W (K99) are available, if the speaker power switch is in position HIGH.
- The load of all speakers has to be added.
  - If the total load of all speakers per channel is higher than the delivered amplifier outlet power, not all speakers may work with the maximum power.
  - If the total load of all speakers per channel is lower than the delivered amplifier outlet power, all speakers may work with the maximum power, a power reserve additionally.
- For an efficient use of the speaker power the optimum impedance in conjunction with the output transformer connection possibilities has to be determined.

		Delivered maximum power in Watt if speakers with an impedance of xx Ohm are connected (F91/K99).						Voltage applied to the terminals in Volt <sub>rms</sub> F91/K99	Terminal number and polarity	
		16Ohm	12 Ohm	8 Ohm	6 Ohm	4 Ohm	2 Ohm		pos	neg
LOW				0.5 F91	0.7/0.2	1/0.3	2/0.6	2/1.1	2	1
			0.7 F91	1 F91	1.3/0.4	2/0.6	3.9/1.1	2.8/1.5	6	5
		1 F91	1.3/0.4	2/0.5	2.7/0.7	4/1.1	8/2.2	4/2.1	3	2
		2.3/0.6	3/0.85	4.5/1.3	6/1.7	9/2.6	18/5.1	6/3.2	3	1
		4/1.2	5.3/1.5	8/2.3	10.7/3.1	16/4.6	32/9.3	8/4.3	5	4
		7.3/2.1	9.7/2.8	15/4.2	19/5.6	29/8.4	58/16.8	10.8/5.8	6	4
HIGH		16/4.6	21/6.2	32/9.3	43/12.3	64/18.5	128/37	16/8.6	4	3
		25/7.2	33/9.5	50/14.3	67/19.1	100/28.6	200/57.2	20/10.7	4	2
		30/8.7	40/11.6	61/17.4	81/23.2	121/34.8	*	22/11.8	4	1
		36/10.4	48/13.9	72/20.8	96/27.7	144/41.6	*	24/12.9	5	3
		49/14.1	65/18.8	98/28.1	131/37.5	196/56.25	*	28/15	5	2
		56/16.2	75/21.6	113/32.4	150/43.2	*	*	30/16.1	5	1
	59/17.4	79/23.2	119/34.9	158/46.5	*	*	30.8/16.7	6	2	
	67/19.4	90/25.8	134/38.7	179/51.6	*	*	32.8/17.6	6	1	

### 13.4 Connection of 70v systems

70V systems are intended for transmissions over long distances. They also have their own transformer in front of the speakers. The primary (input-)side of this transformer has to be connected in correct polarity with the 70V terminals of the Deutsche Wurlitzer GmbH output transformer. It is not allowed to consume more power than the amplifier is able to supply (23W or 45W), minus the additional speakers eventually connected to the output transformer. At some 70V-systems the load is capable of variation.

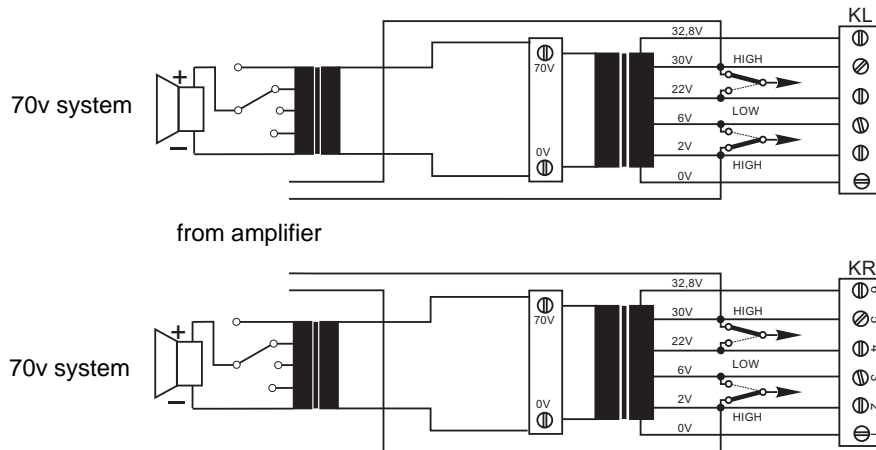

# 14 Technician Statistics

## 14.1 Service data, level 4 button 8

Special data for the jukebox service are displayed in service level 4 button 8. By pressing the button 8 several times you can call up the contents of up to 18 different storage locations stored in the below explained statistical values.

These data are useful to assess the condition of the jukebox and its mechanism.

1. Set the slide switch 'service' at the SCC-unit to ON.
2. Press 'LT' button.
3. Press selection button R -hold down- and press selection button 0 than release both buttons.
4. Press selection button 4. Service level 4 is reached. Display shows: 4\_ \_ \_.

### 14.1.1 Retrieval of the last occurred mechanism faults

The SCC unit stores up to 9 of the last occurred mechanism error codes (procedure step codes) If more errors have occurred only the latest 9 are stored.

1. Press selection button 8, display shows flashing:  
⇒ 1 = 1st error code

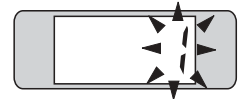

- then eg.  
⇒ 1st error code is always 000  
(memory check).



2. Press selection button 8 again, display shows flashing:  
⇒ 2 = last occurred error code

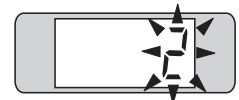

- then e.g.  
⇒ Error 160: Error when reaching the vertical take out position.



3. Press selection button 8 once more to display the next error code etc. After displaying the 10th code, special values will be displayed (ref to the following chapters).
4. DELETE this data: Press selection button 8 - hold - and press button R.
5. Exit: Press button R.



**Procedure step codes for 'CD to turntable':**

in rest	in action	meaning
32	160	selection sledge has reached the vertical 'take out position'
33	161	open gripper (before taking a CD)
34	162	move gripper into magazine
35	163	close gripper (get a CD)
36	164	get a CD from magazine and move to the vertical transport level (LH or RH side)
37	165	move the CD player - move sledge to player unit
38	166	move gripper to the horizontal player position
39	167	move sledge with CD to the player
40	168	open gripper (release CD)
41	169	move gripper out of player range
42	170	fix the CD with the puck
43		CD on player, end of procedure

**Procedure step codes for 'CD to magazine':**

in rest	in action	meaning
16	144	get vertical sledge position over the player
17	145	move gripper horizontal to take the CD
18	146	close gripper
19	147	lift CD
20	148	move to vertical transport level
21	149	move sledge to magazine return position
22	150	move gripper with CD into magazine
23	151	open gripper
24	152	move gripper out of magazine
25	153	move sledge to 0-position
26		CD is taken back, end of procedure

**14.1.2 Counter for complete mechanism cycles**

After the end of each replacing procedure the counter will be incremented. This information given in the steps 11 and 12 of service level 4 button 8 will be displayed with 8 digits. Because of a four digit display, this value will be displayed in two parts the 4 higher and the 4 lower digits. To display the complete value:

1. Press selection button 8 as often as, display shows flashing:  
⇒ 11 = next displayed value are the 4 high value digits of the mechanism counter

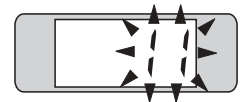

- then e.g.  
⇒ value, means 1 60 0000



2. Press selection button 8 again, display shows flashing:  
⇒ 12 = next displayed value are the 4 low value digits of the mechanism counter



- then e.g.  
⇒ value, means 3 467



In this example the machine has placed and replaced the CDs 1,603,467 times.

**14.1.3 Counter for total number of mechanism faults**

Each mechanism error will be counted. This information given in the steps 13 and 14 of service level 4 button 8 will be displayed with 8 digits too. To display the complete value:

1. Press selection button 8 as often as, display shows flashing:  
 ⇒ 13 = next displayed value are the 3 high value digits of the error counter

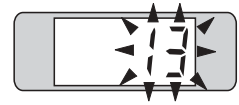

then e.g.  
 ⇒ value



2. Press selection button 8 again, display shows flashing:  
 ⇒ 14 = next displayed value are the 3 low value digits of the error counter

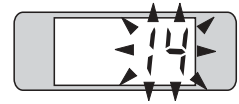

then e.g.  
 ⇒ value. In this example 250 errors have occurred.



**14.1.4 Counter for total number of power up's**

Each power up will be counted. This information given in the steps 15 and 16 of service level 4 button 8 will be displayed with 8 digits too. To display the complete value:

1. Press selection button 8 as often as, display shows flashing:  
 ⇒ 15 = next displayed value are the 4 high value digits of the power up counter

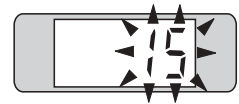

then e.g.  
 ⇒ value



2. Press selection button 8 again, display shows flashing:  
 ⇒ 16 = next displayed value are the 4 low value digits of the power up counter



then e.g.  
 ⇒ value. In this example the power was switched on 10023 times.



**14.1.5 Counter for total operating time**

The operating time displayed in the steps 17 and 18 of service level 4 button 8 will be displayed in minutes with 8 digits too. To retrieve the complete value:

1. Press selection button 8 as often as, display shows flashing:  
 ⇒ 17 = next displayed value are the 4 high value digits of the operating time counter



then e.g.  
 ⇒ value



2. Press selection button 8 again, display shows flashing:  
 ⇒ 18 = next displayed value are the 4 low value digits of the operating time counter



then e.g.  
 ⇒ value. In this example the total operating time is 241453 minutes (approx. 4024 h).



## 15 Function tests

The function tests are divided in 3 groups. Display test (level 1), mechanism tests (level 4) and player tests (level 5).

### 15.1 Digital display test / EPROM-version, level 1 button 4

1. Set the slide switch 'service' at the SCC unit to ON.
2. Press 'LT' button. Display shows e.g.: \_ 4 0 9 (409 or higher = SCC program version)
3. Press selection button R -hold down- and press selection button 0 than release both buttons. The display is dark.
4. Press selection button 1. Service level 1 is reached. Display shows: 1 \_ \_ \_.
5. Press selection button 4.  
⇒ All segments counting 0 to 9 are displayed, then the program version number (EPROM version).
6. To cancel the procedure press selection button R.

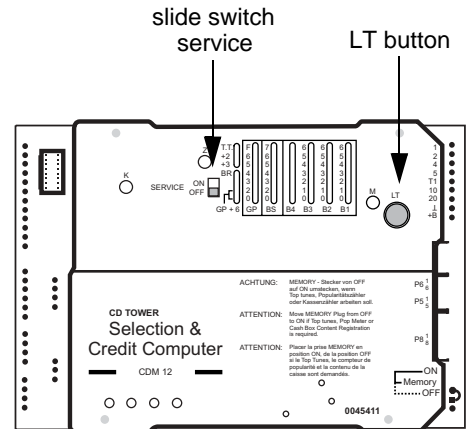

### 15.2 Mechanism single step tests

Service level 4 includes all functions to check the CD-2 mechanism. Single step and continuous tests can be made.

1. Set the slide switch 'service' at the SCC unit to ON.
2. Press 'LT' button. Display shows e.g.: \_ 4 0 9 (409 or higher = SCC program version)
3. Press selection button R -hold down- and press selection button 0 than release both buttons. The display is dark.
4. Press selection button 4. Service level 4 is reached. Display shows: 4 \_ \_ \_.

#### 15.2.1 Take CD to turntable, level 4 button 0

Press selection button 0 and enter the desired CD number.

This function is not supported by program versions below 4.09!

#### 15.2.2 Step selection sledge upwards, level 4 button 2

Press selection button 2. The button has an auto repeat function.

Each button operation makes the sledge move one step upwards and the display will be increased by 2. Last position is 120.

If both magazines exist, the left one will be used as reference. If the L.H. magazine is missing the other one is used.

**15.2.3 Step selection sledge downwards, level 4 button 1**

Press selection button 1. This button has an auto repeat function.

Display shows \_\_ 0 0:

If the display is still 0 0, the selection sledge (german: AusWahlSchlitten - AWS) is located in its lowest position (basic position). It is impossible to move it further down. It can only be moved if the sledge has been moved up with selection button 2 before. Then the display will also show a greater number as 0 0, e.g.: 22.

Display shows a number greater than 0 0, e.g.: \_\_ 2 4

Each button operation makes the sledge move one step downwards and the display will be decreased by 2. Last position is 02.

**15.2.4 Get a CD from LH magazine, level 4 button 3**

**WARNING!** After having taken the CD to the turntable the SCC automatically jumps to service level 5! You only can jump back to SL 4 by pressing the button 3 to run the procedure 'STOP and back to SL 4'.

Press selection button 3. A CD is taken from the actual sledge/CD position and placed on the turntable. The service program automatically jumps to service level 5.

**15.2.5 Get a CD from RH magazine, level 4 button 4**

**WARNING!** After having taken the CD to the turntable the SCC automatically jumps to service level 5! You only can jump back to SL 4 by pressing the button 3 to run the procedure 'STOP and back to SL 4'.

Press selection button 4. A CD is taken from the actual sledge/CD position and placed on the turntable. The service program automatically jumps to service level 5.

**15.2.6 Mechanism continuous tests, level 4 button 9**

To locate certain faults occurring only from time to time it may be helpful to run continuous tests. During the tests described below, the display shows special procedure step codes. These codes are divided in rest and action codes (ref. to the table opposite).

If the machine stops at a certain point in conjunction with these codes you can determine the point of fault. In this case you should switch off the jukebox and try to find the reasons of this fault. Then you have to take the selection sledge in its home position by hand. Home position means: The position of the magnetic pressure disc is approx. 1 cm (1/2 ") over the player and the gripper motor stays on the RH side of the pressure disc holder. The LH edge of the gripper holder should align with the RH edge of the pressure disc holder. Then switch on the jukebox. It now initializes itself.

**Test start:** Press selection button **9** -hold- and press button **R**. Release all buttons.  
**Press selection buttons 1, 2, 3 or 4, according the table 'continuous test procedures'.** The continuous test starts.

**Test stop:** Press selection button **9**.

**All continuous tests can be switched to single step mode while running:**

**Single step - ON:** Press selection button 5.  
The just running step runs to its end. The machine waits.

**Single step - NEXT:** Press selection button 5 again.  
Only the next one step runs. Press button 5 again etc.

**Single step - OFF:** **Press selection button 6.**

**Continuous test procedures**

Selection button 1	CD changer test Remove all CDs and insert only the CDs no. 119 and 120 !	The gripper takes the CD from compartment 119, takes it to the turntable and back to compartment 099! Now the gripper takes this CD to the turntable and back to compartment 079 e.t.c.. At the end the gripper takes the CD back to comp. 119. Then the same procedure starts on the RH side with CD 120. If an error occurs the machine will stop displaying the corresponding error code.
Selection button 2	gripper test	The gripper opens and closes continuously.
Selection button 3	takes the CD no. 30 to and from the turntable	
Selection button 4	takes the CD no. 29 to and from the turntable	

**Procedure step codes**

in rest	in action	meaning	
16	144	get vertical sledge position over the player	
17	145	move gripper horizontal to take the CD	
18	146	close gripper	
19	147	lift CD	
20	148	move to vertical transport level	
21	149	move sledge to magazine return position	
22	150	move gripper with CD into magazine	
23	151	open gripper	
24	152	move gripper out of magazine	
25	153	move sledge to 0-position	
26		CD is taken back, end of procedure	
32	160	selection sledge reaches the vertical 'take out position'	
33	161	open gripper (before taking a CD)	
34	162	move gripper into magazine	
35	163	close gripper (get a CD)	
36	164	get a CD from magazine and move to the vertical transport level (LH or RH side)	
37	165	reach the CD player - move sledge to player unit	
38	166	move gripper to the horizontal player position	
39	167	move sledge with CD to the player	
40	168	open gripper (release CD)	
41	169	move gripper out of player range	
42	170	fix the CD with the pressure disc	
43		CD on player, end of procedure	
48	176	attempt to move the selection sledge to the player	
49	177	initialize the magazines (count to 6161)	<b>to initialize</b>
50	178	move the sledge to the player, after initialization	
80	208	close gripper	<b>gripper</b>
81	209	open gripper	
	112	check sum error in memory for CD2 mechanism (e.g. after 'battery off operation')	
	126	error while error was handed	<b>errors</b>
	254	total error, e.g. defective RAM or CPU...	

CD back to compartment

CD to turntable

FIELD SERVICE MANUAL

### 15.3 Light gate tests

Five light gates are used to position the selection sledge. These sensors scan certain movements. The name of a light gate corresponds to the principal movement.

1. Vertical-Lineal-Left (VLL), movement LH side
2. Horizontal-Lineal-Left (HLL), movement LH side
3. Vertical-Lineal-Centre (VLC), movement center
4. Horizontal-Lineal-Right (HLR), movement RH side
5. Vertical-Lineal-Right (VLR), movement LH side

#### 15.3.1 Light gate snapshot, level 4 button 7

To start the test: Press selection button 7.

By pressing selection button 7 a 'snapshot' of the actual gate state will be made. Then this state will be displayed in a coded form.

An interrupted gate sends a '0' to the corresponding digit in the display.

Two gates are combined in the second and fourth digit (from RH side) of the display.

Both left and right gates (VLL, VLR) send a '2' if open to the corresponding digit, the others a '1'. This value adds itself.

The RH digit is always 0.

To exit the test: Press selection button R.

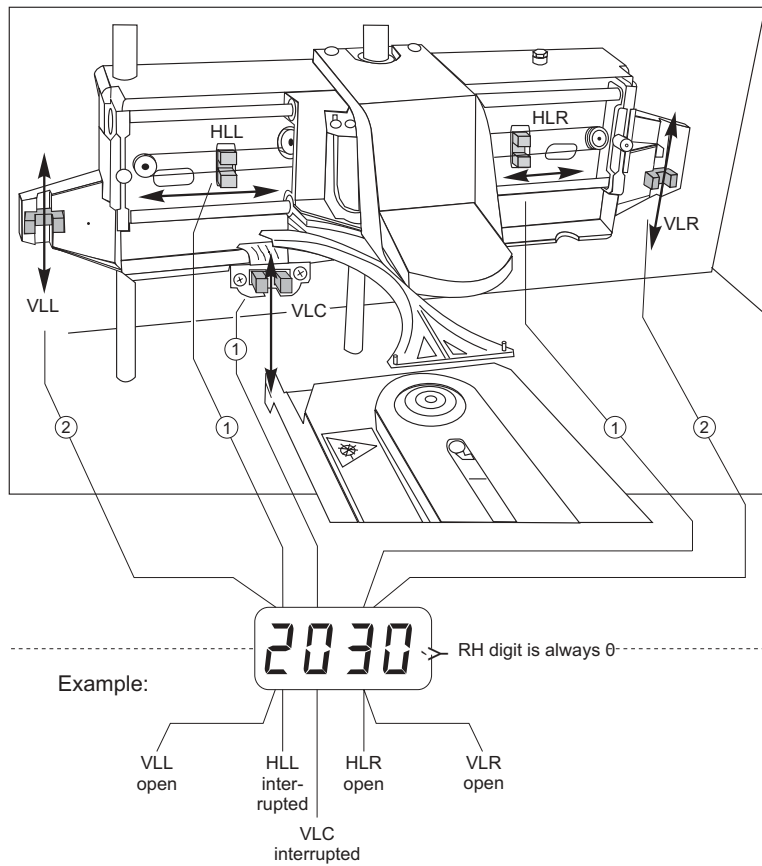

### 15.3.2 Light gate function test, level 4 button 9

With this test you can check each single light gate by a continuous test loop during operation. A “0” in the display represents an open gate, a “1” represents a closed one. The gate to be checked is connected by software to the interrupt request line INT1 which is used in normal operation. INT1 is always shown in the most RH digit of the display. So do not worry that the left movement VLL is displayed in the second digit from right.

**Test start:** Go to service level 4 press selection button 9 - hold - and press selection button R. Release both buttons and press selection button 9 again. The display shows:

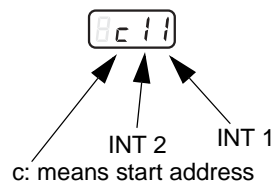

Now you can select different test procedures. Each procedure checks a certain function and the corresponding light gate. The procedures are numbered from 0 to 9 and can be selected with the selection buttons 1 (counts downwards) and 2 (counts upwards). The procedures 7, 8 and 9 have no function.

Depending on the selected test you can carry out special actions by means of the selection buttons 3 and 4. If you use the selection buttons 5 or 6 each action will be stopped at an occurring bright dark or dark bright change (auto edge stop) of the gate.

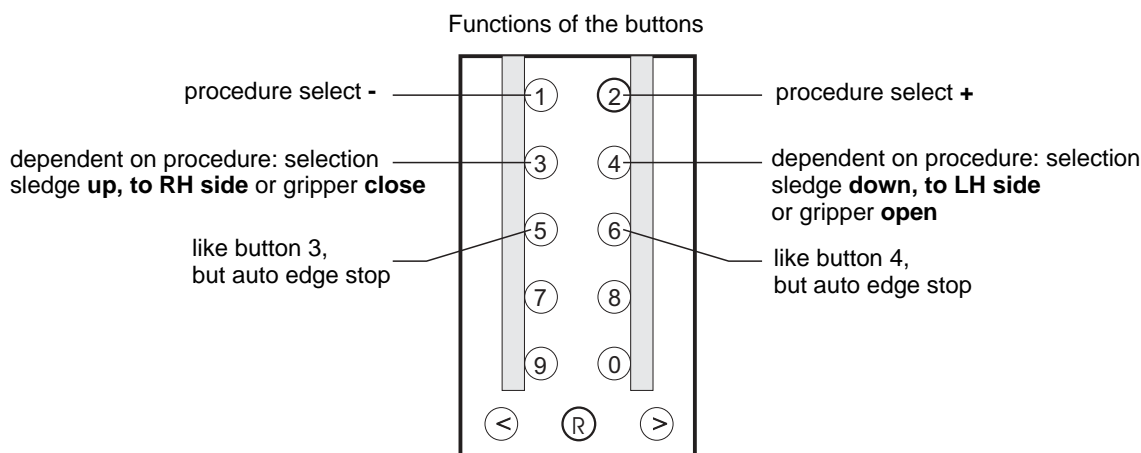

#### Meaning of the tests:

0 Test: VLL & VLR together. VLL is displayed in the RH digit (INT1), VLR in the second digit from RH (INT2). 1=gate is interrupted, 0=gate is open. Button 3 (5) makes the selection sledge move downwards, button 4 (6) upwards.

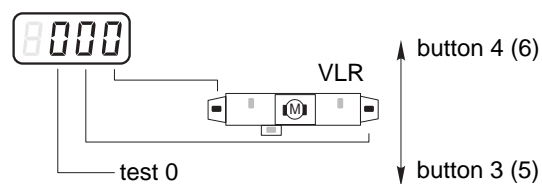

1 Test: VLR. State is displayed in the RH digit (INT1). 1=gate is interrupted, 0=gate is open. Button 3 (5) makes the selection sledge move downwards, button 4 (6) upwards.

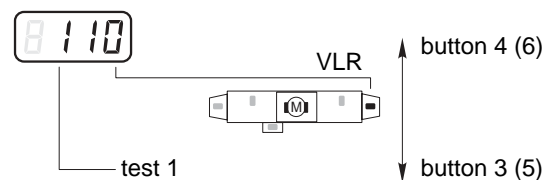

2 Test: VLC (Center). State is displayed in the RH digit (INT1). 1=gate is interrupted, 0=gate is open. Button 3 (5) makes the selection sledge move downwards, button 4 (6) upwards.

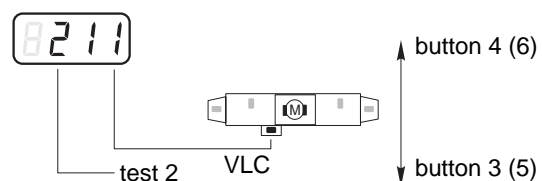

3 Test: VLL . State is displayed in the RH digit (INT1). 1=gate is interrupted, 0=gate is open. Button 3 (5) makes the selection sledge move downwards, button 4 (6) upwards.

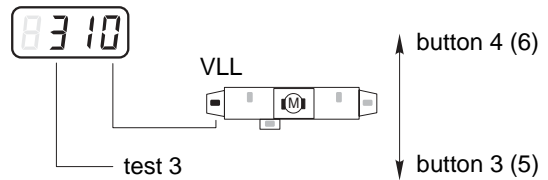

4 Test: VLL . State is displayed in the RH digit (INT1). 1=gate is interrupted, 0=gate is open. Button 3 (5) makes the gripper move to the LH side, button 4 (6) to the RH side.

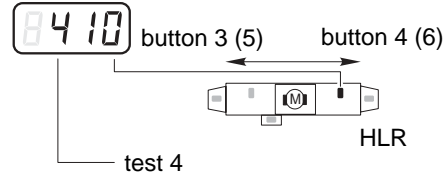

5 Test: HLL . State is displayed in the RH digit (INT1). 1=gate is interrupted, 0=gate is open. Button 3 (5) makes the gripper move to the LH side, button 4 (6) to the RH side.

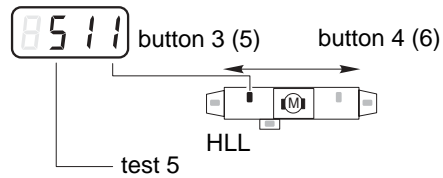

6 Test: Gripper. State is displayed in the RH digit (INT1). 1=gate is interrupted, 0=gate is open. Button 3 (5) opens the gripper, button 4 (6) closes it.

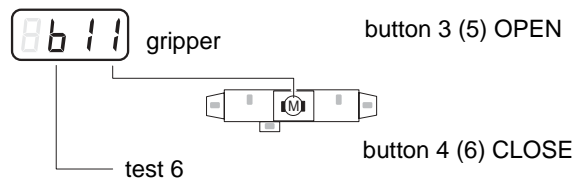

## 15.4 CD-PRO function tests, level 5

The following tests can be done in service level 5. In some cases level 5 is reached automatically (see 14.1.4, page 64), because these tests are parts of complete test procedures.

1. Set the slide switch 'service' at the SCC unit to ON.
2. Press 'LT' button. Display shows e.g.: \_ 4 0 9 (409 or higher = SCC program version)
3. Press selection button R -hold down- and press selection button 0 than release both buttons. The display is dark.
4. Press selection button 5. Service level 5 is reached. Display is: 5\_ \_ \_.

### 15.4.1 CD player check (START), level 5 button 6

Before starting this test a CD has to be placed on the turntable (ref to chap. 7.2.4.). If no track has been selected with the buttons 0 or 9 the complete CD will be played.

Press selection button 6, the CD will start to play beginning with the first track. The display shows at first:



TRACK number

then the current play time in sec.:



PLAY TIME  
(here: 8sec.)



**WARNING!** Showing the play time in this test is an important indicator for the serial communication between the SCC unit and the CD controller!



**15.4.2 NEXT, level 5 button 0**

Service level 5 has to be reached and a CD has to be placed on the turntable (ref. to chap. 7.2.4).

Press selection button 0 (several times). The CD starts and the track number according to the number of key actuations will be played. Only this track will be played. The digital display shows at first e.g.:



TRACK number

then the current play time in sec (e.g. 8 sec).

- If selection button 0 is pressed again once the next track will be played or
- if selection button 6 is pressed the remaining tracks of the CD will be played.

PLAY TIME  
of actual track**15.4.3 PREVIOUS, level 5 button 9**

Service level 5 has to be reached and a CD has to be placed on the turntable (ref. to chap. 7.2.4.).

Press selection button 9 (several times too).

The player jumps to the previous track with each button actuation. If track 1 is reached it will be played continuously. If button 6 is pressed in between, the remaining tracks of the CD will be played.

**15.4.4 STOP, level 5 button 5**

Press selection button 5. CD stops playing. Display shows 5 \_ \_ \_ (service level 5).

**15.4.5 STOP playing and go back to level 4 (level 5 button 3)**

Press selection button 3. CD stops playing. Display shows 4 \_ \_ \_ (service level 4).



**NOTE:** To terminate all the tests and return to normal operation: Set slide switch 'SERVICE' on the SCC unit to OFF. Press 'LT' button also on the SCC unit.

## 16 Integrated test program of the CD-PRO player

### 16.1 Access to the player functions without S&CC unit

For a test the complete player unit CD-PRO can be operated without S&CC unit.

The power supply from the installed amplifier, the sub-transformer and an amplifier with CD input for the audio signal is required.

A one digit digital display indicates the current operation mode and three command buttons are located on the player chassis.

The one digit display is able to display more information.

To display two or more digits the information starts with a dark phase of approx. 1 sec. followed by the digits shown one after another with dark phase of 100 msec. between each digit.

After power on and after a general reset command (display shows "8"), the program version number of the Deutsche Wurlitzer GmbH CD control unit will be displayed with four digits followed by the version number of the CD-PRO servo processor with two digits.

If the player is in stand by and the three buttons on the player are pressed at the same time the above mentioned sequence will be displayed but without showing "8" for "reset active".

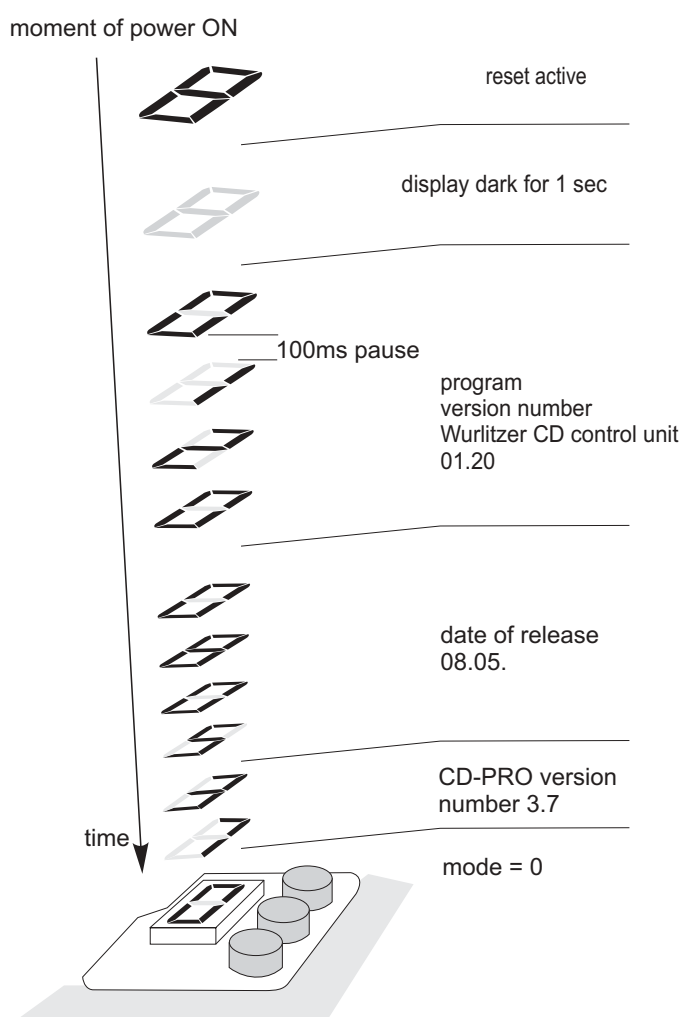
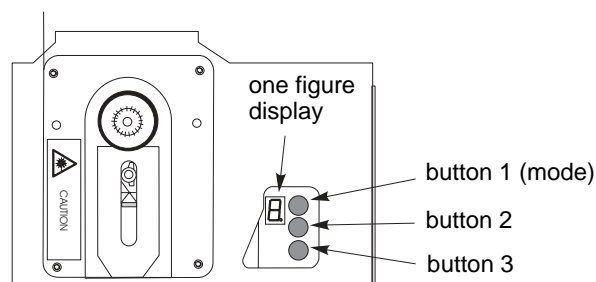

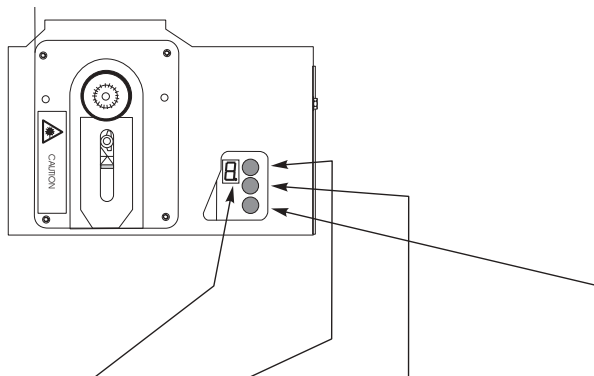

## Test functions CD-PRO

(Example: If mode display = 3 and button 2 will be pressed, then pause is switched on.)

mode display	button 1 (mode)	button 2	button 3	buttons 2 + 3 together
0	mode 1	start	stop	repeat CD
1	mode 2	next track	previous track	repeat track
2	mode 3	search forward	search backward	single, double speed.
3	mode 4	pause ON	pause OFF	
4	mode 5	volume +	volume -	mute
5	mode 0	track +1	track -1	play selected track (read TOC if necessary)

If “repeat CD” had been selected with the buttons 2 + 3 in mode 0 the display will be “99”. At each beginning of a new track it will be displayed with two digits.

If “repeat track” had been selected with the buttons 2 + 3 in mode 1 the actual played track will be displayed.

By pressing of two buttons at the same time additional values will be displayed:

Buttons 1+2: The last occurred error code will be displayed (ref. to error code table). This error code will be reset after this retrieval or after a CD-PRO reset (e.g. the next power on).

Buttons 1+3: The actual playing track will be displayed.

Buttons 1+2+3:

a) No CD is playing: Program version and date of release.

b) CD is playing: Max. / min. track number will be displayed.



**NOTE:** If commands will be sent to the CD-PRO player, the display will flash. During this time no commands given by the buttons will be accepted. While the table of contents (TOC) is read an 8 flashes in the display. In this way, the necessary time to read the TOC can be prolonged. So bad CDs can be recognised and taken out.

Error code	Meaning
0	No error
2	Focus error or no disc
7	Subcode error, no valid subcode
8	TOC error
10	Radial error
12	Fatal sledge error
13	Turntable motor error
31	Search time out
32	Search binary error
33	Search index error
34	Search time error
40	Illegal command
41	Illegal value
42	Illegal time value
43	Communication error
44	Reserved
45	HF detector error
48	Emergency stop

## 16.2 Special test functions of the CD-PRO player

Service program of CD-PRO (mode 9). With this service program different functions of the CDM12 player can be tested.

**How to call:**

Switch main power OFF. Press button 1 - hold down - and switch main power on. (Remark: "Power ON - OFF" can also be done by disconnecting the wire bk./gy. from pin 6 of the sub transformer.)

**Function:**

The CD control unit steps into mode 9 and runs the tests 90 up to 99. Mode 9 will be displayed continuously. While changing the test step it will be displayed with two digits

**Remarks:**

For starting test step 94 a CD has to be placed on turntable.

The button 1...

has no function during this test.

The button 2...

switches to the next test step.

The button 3...

switches to the previous test step.

**Quit:**

Press button 2 while test 98 is running. Control unit steps over test 99 to mode 0 automatically.

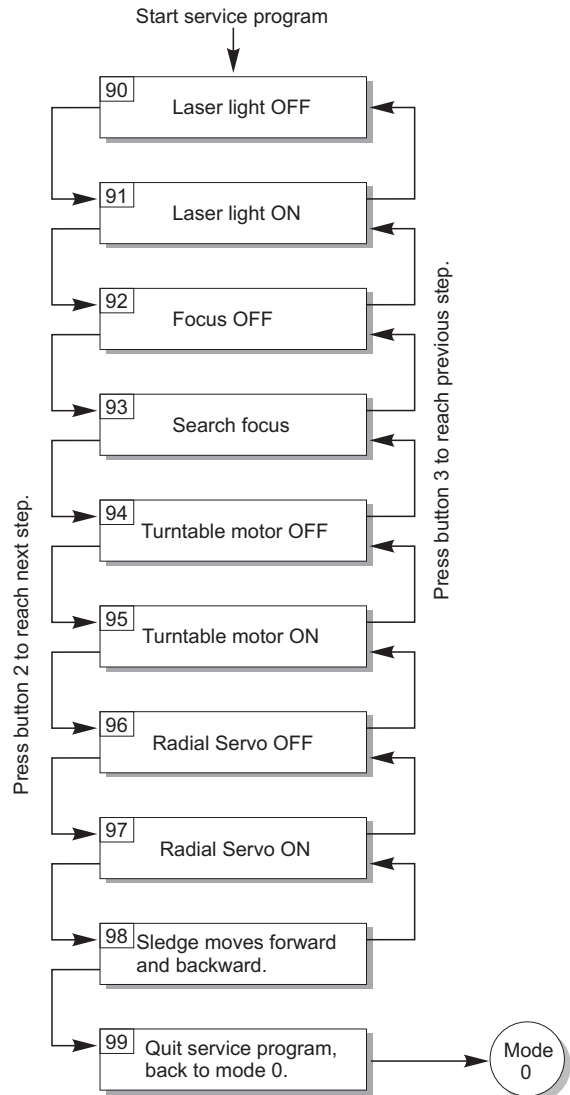

**Test 91:** You can check the laserlight with an infrared indicator.

**Test 93:** Without a CD: laser lense moves up and down. If you put a CD on the turntable while the test runs the lens stops moving if it finds the focus point.

**Test 95:** The turntable motor must spin.

**Test 98:** The sledge moves itself from inside to outside and back again. If this test is successful the speed of the disc must change to lower speed at the outside of the disc.

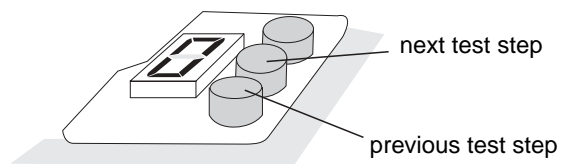

## 17 Accessories

### 17.1 Microfone kit (part no. 0006953)

This unit enables the use of the jukebox as a paging system, when playing as well as during idling periods. If the paging microphone is switched on while the jukebox is playing, the music will be muted for this period. This kit is to be connected at the microphone socket of the amplifier. The length of the cable between mike pre-amp and the jukebox is approx. 45 ft / 15 m.



### 17.2 BGM-Connector

This equipment offers two features:

1. The sound of an external source (300mV - 1V), e.g. radio or tape, will be reproduced over the speakers of the jukebox with adjustable volume. A selection over the jukebox will mute this source, and it returns only after all selections have been played. (Time-lag can be adjusted).
2. Connecting the jukebox to an existing background system (amplifier), the sound of this equipment is switched off as long as the jukebox is playing. The hook-up for this adapter is the same as the microphone.

BGM connector kit, part no. 0048130.

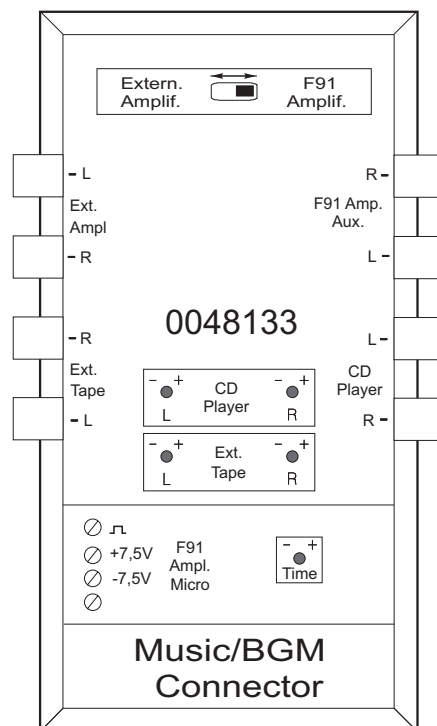

## 18 Steps to solve mechanical problems

In case of a mechanical error the software tries to solve the problem itself. If this is not successful the mechanism switches itself off. Then the display shows an error code (ref. to chapt. 7.3. page 64). The jukebox is then out of order.

### 18.1 Treating simple errors

Switch the jukebox off and on several times. (The software tries to solve the problem again.) No success ? Step to chapter 18.2.

### 18.2 Treating simple errors by hand

1. Switch off the jukebox
2. Move the gripper by pressing against the motor as far as the CD can be taken out by hand.
3. Take the CD out of the gripper.
4. Insert the CD in the corresponding compartment.
5. Switch on the jukebox, it will be run automatically:
  - ⇒ Error elimination
  - ⇒ Initializing phase
  - ⇒ jukebox ok.
6. No success ? Step to chapter 18.3.

### 18.3 Set the mechanism to '0' position

1. Power OFF!
2. Open the Jukebox.
3. Open the mechanism housing, replace any CDs that may have been dropped.
4. Move gripper to RH. 0-position.
  - ⇒ Move, by pressing against the gripper motor, gripper holder of selection sledge so that LH. side of gripper holder aligns with RH. side of pressure disc holder.
  - ⇒ If RH. position impossible:
  - ⇒ Move gripper to the LH. 0-position, so that right edge of gripper holder aligns with LH side pressure disc holder.
5. Remove the left magazine. (to reach the gear).
6. Position of the selection sledge.
  - ⇒ The sledge has to be at least 1,3 " (3 cm) over the housing bottom. Therefore move the sledge up and down by hand using the toothed belt wheel on the top LH. side of gear group.
7. Insert the left magazine.

8. Check the fixing of the magazines by hand.
9. Close the mechanism housing.
10. Set the slide switch 'SERVICE' on the SCC unit to ON.
11. Power ON.
12. Delete the stored data of the jukebox.
  - ⇒ Press 'LT' button
  - ⇒ Press 'LT' button again and hold it for at least 6 sec.Followed by:
  - ⇒ an automatic orientation phase
  - ⇒ an automatic initialization phase
  - ⇒ the display of the program version
13. Programming
  - ⇒ insert CDs if necessary
  - ⇒ program number of inserted CDs in service level 1 button 5 as follows:
14. Press selection button R -hold down- and press selection button 0 than release both buttons.
  - ⇒ Press selection button 1. Service level 1 is reached. Display is: 1\_ \_ \_.
  - ⇒ To reprogram press selection button 5 -hold down- and press selection button R. Enter the desired number of CDs with two digits. (expection: 100 CDs = 00)
  - ⇒ program options as desired
15. Switch to normal operation mode
  - ⇒ Set the slide switch 'SERVICE' on the SCC unit to OFF.
  - ⇒ Press 'LT' button on the SCC unit once.
16. Close the jukebox.

## 19 Declaration of Conformity

Konformitätserklärung – Declaration of Conformity – Déclaration de Conformité		
<b>Geräteart:</b> <b>Product Description:</b> <b>Description Du Produit:</b>	Musikbox Jukebox Juke-box	
<b>Typenbezeichnung:</b> <b>Model No.:</b> <b>Modèle No.:</b>	<b>PRINCESS</b>	
<b>Angewandte EG-Richtlinien:</b> <b>Directives Complied with:</b> <b>Directives de la CE:</b>	73/23/EEC	Niederspannungsrichtlinie Low voltage directive Directive relative aux appareils à basse tension
	89/336/EEC	Elektromagnetische Verträglichkeit EMC Directive Directive Relative à la compatibilité électromagnétique
<b>Technische Vorschriften:</b> <b>Standards used:</b> <b>Régulation Technique:</b>	EN 50081-1	Elektromagnetische Verträglichkeit Fachgrundnorm Störaussendung Electromagnetic compatibility Generic Emissions Requirements Compatibilité électromagnétique Norme générique émission
	EN 50082-2	Elektromagnetische Verträglichkeit Fachgrundnorm Störaussendung Electromagnetic Compatibility Generic Emissions Requirements Compatibilité électromagnétique Norme générique émission
	EN 60335-1	Sicherheit elektrischer Geräte für den Hausgebrauch und ähnliche Zwecke Safety of household and similar Electrical appliances Sécurité des appareils électrodomestiques et analogues
	EN 60335-75	Grenzwerte und Messverfahren für Funkstörungen von informationstechnischen Einrichtungen Limits and methods of measurement of radio interference characteristics of information technology equipment Sécurité des appareils électrodomestiques et analogues
	EN 55022	Grenzwerte Und Meßverfahren Für Funkstörungen Von Informationstechnischen Einrichtungen Limits And Methods Of Measurement Of Radio Interference Characteristics Of Information Technology Equipment.
Unterschrift/Signature/ Signature		
Gedruckter Name/Print name/nom	Jürgen Obermeier	
Position/Position/Position	Chief Engineer/Technischer Leiter/Directeur Technique	
Datum/Date/Date	2. Januar 1998/2. January 1998/2. Janvier 1998	





# WURLITZER®

**Germany**

Deutsche Wurlitzer GmbH  
Wurlitzerstraße 6  
D-32609 Hüllhorst  
Tel.: +49 (0) 57 44 - 941-0  
Fax: +49 (0) 57 44 - 941 220  
[contact@deutsche-wurlitzer.de](mailto:contact@deutsche-wurlitzer.de)

Wurlitzer® A Registered Trademark of the Gibson Guitar Corporation

Part no.: 0071126  
Edition 4708