

Fig.6: Install the parts on the PC board as shown here but don't install IC2 or IC3 until after the initial checks described in the text have been made.

detected a problem. In that case, go to the "Fault Codes" panel to find out what to check for.

At this point, you can mount the test lead sockets onto the front panel – see Fig.7. Note that plastic insulating rings

are supplied with these sockets. As shown in Fig.7, these must be installed between the lugs and the front panel, not under the tops of the sockets. Many constructors of the Mk.1 version overlooked this and placed the lugs directly on the

metal panel, thereby short-circuiting them! Also refer to Fig.11 for correct socket mounting.

Next, mount the pushbutton switch, using small pliers to gently tighten the nut and being careful not to slip and scratch the panel. That done, fasten the standoffs to the board using 3mm screws, then mount the whole assembly on the front panel using the black countersunk 3mm screws supplied. If the LED displays foul the Perspex window, use the supplied washers to further space the board from the front panel.

Finally, complete the assembly by connecting the wires to the pushbutton switch and test lead sockets, and by soldering the supply leads to the battery holder. See Fig.10a & 10b.

Calibration

Now for the calibration. The step-by-step procedure is as follows:

(1) Plug in the test leads, then push the button. You should see “-” on the left-hand display, indicating that the meter is seeing an ESR/resistance that's greater

Table 1: Resistor Colour Codes

Value	4-Band Code (1%)	5-Band Code (1%)
470kΩ	yellow violet yellow brown	yellow violet black orange brown
220kΩ	red red yellow brown	red red black orange brown
100kΩ	brown black yellow brown	brown black black orange brown
47kΩ	yellow violet orange brown	yellow violet black red brown
15kΩ	brown green orange brown	brown green black red brown
10kΩ	brown black orange brown	brown black black red brown
6.8kΩ	blue grey red brown	blue grey black brown brown
4.7kΩ	yellow violet red brown	yellow violet black brown brown
2.7kΩ	red violet red brown	red violet black brown brown
2.2kΩ	red red red brown	red red black brown brown
1kΩ	brown black red brown	brown black black brown brown
680Ω	blue grey brown brown	blue grey black black brown
220Ω	red red brown brown	red red black black brown
180Ω	brown grey brown brown	brown grey black black brown
100Ω	brown black brown brown	brown black black black brown
68Ω	blue grey black brown	blue grey black gold brown
5.6Ω	green blue gold brown	green blue black silver brown

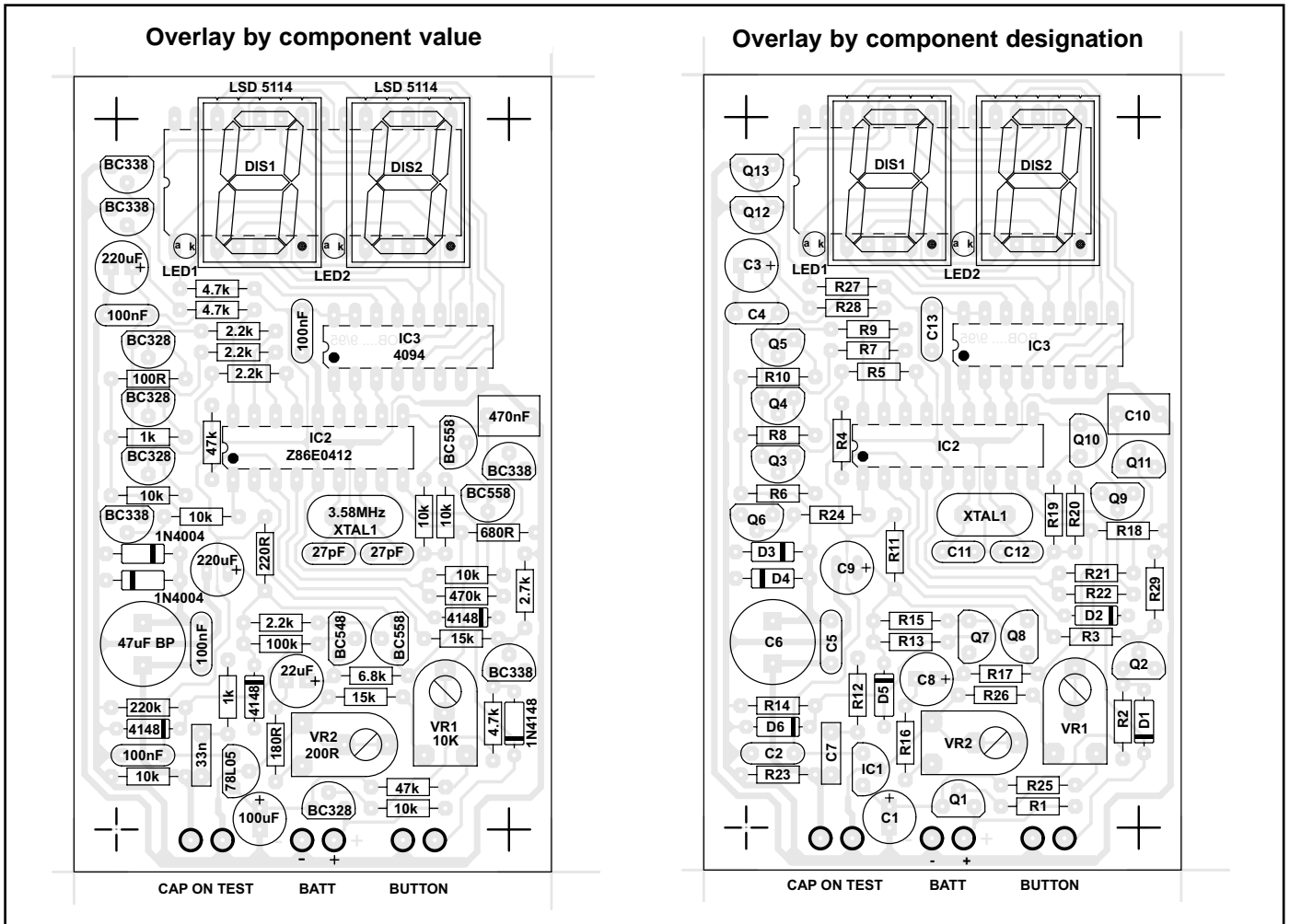

Fig.9a & 9b: Shows the PCB overlay with both component values and component designations. This can be very helpful in a service or fault-finding situation when the constructor needs to cross-reference between the two.

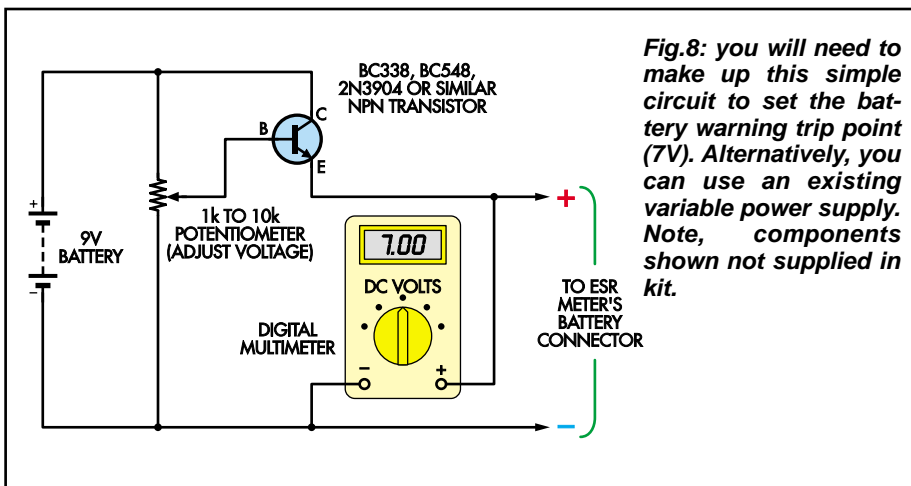

Fig.8: you will need to make up this simple circuit to set the battery warning trip point (7V). Alternatively, you can use an existing variable power supply. Note, components shown not supplied in kit.

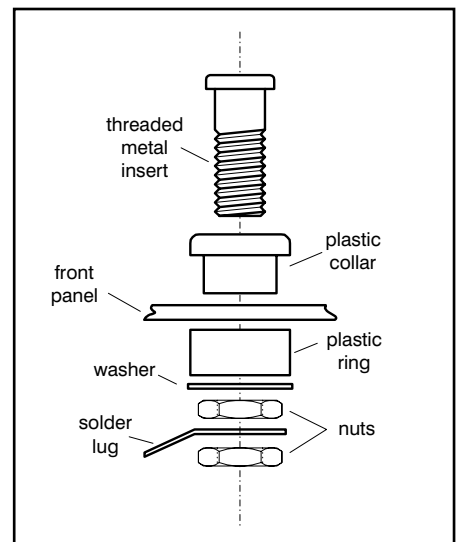

Fig.11: The front panel is mounted between the plastic collar and ring of the banana socket. Then two nuts are used to hold and lock the assembly in place.

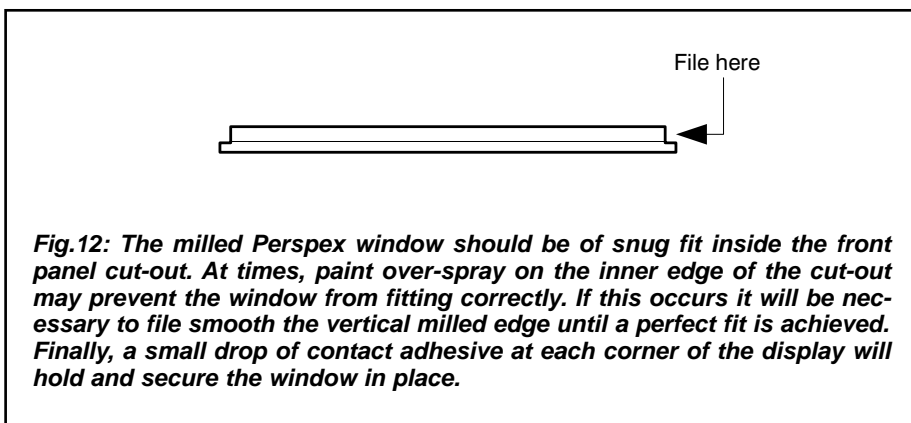

Fig.12: The milled Perspex window should be of snug fit inside the front panel cut-out. At times, paint over-spray on the inner edge of the cut-out may prevent the window from fitting correctly. If this occurs it will be necessary to file smooth the vertical milled edge until a perfect fit is achieved. Finally, a small drop of contact adhesive at each corner of the display will hold and secure the window in place.



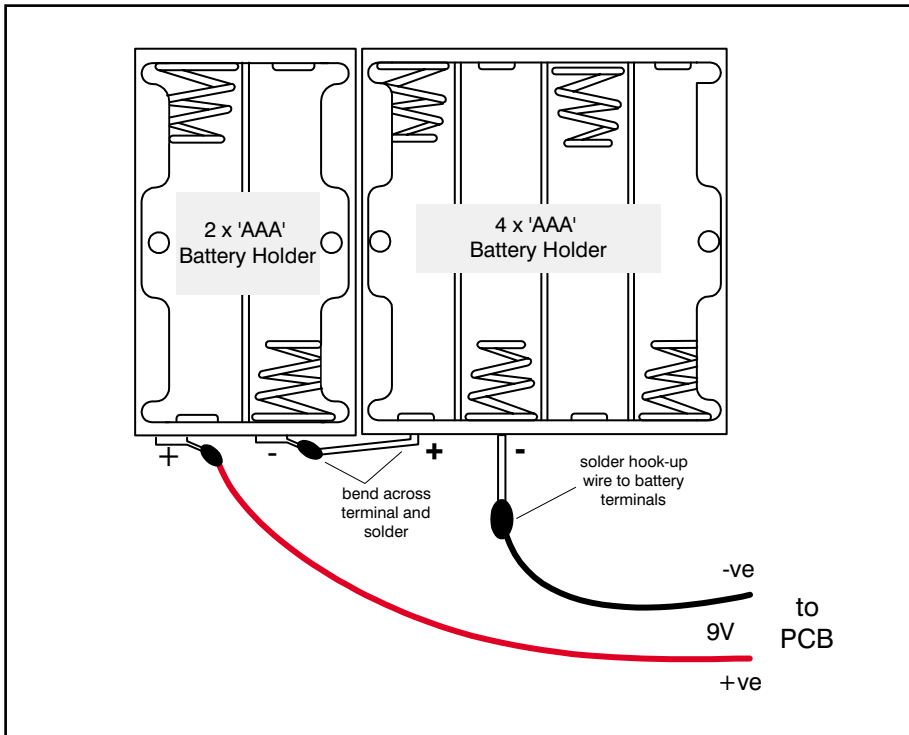

Fig.10a: Two battery holders connected in series are used for the battery source. Connect and solder the inner terminals as shown, then solder a short length of hook-up wire to each of the outer terminals completing the positive (+ve) and negative (-ve) supply leads.

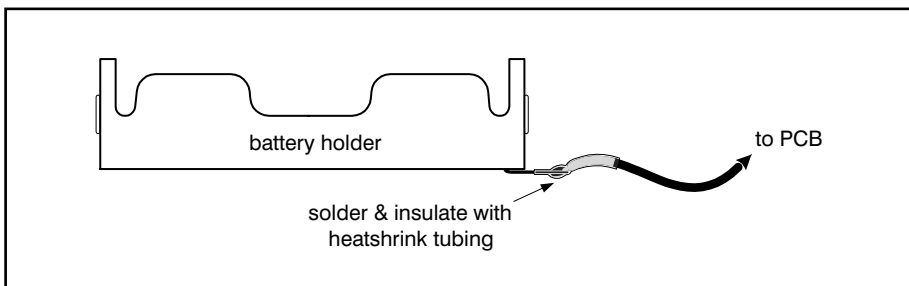
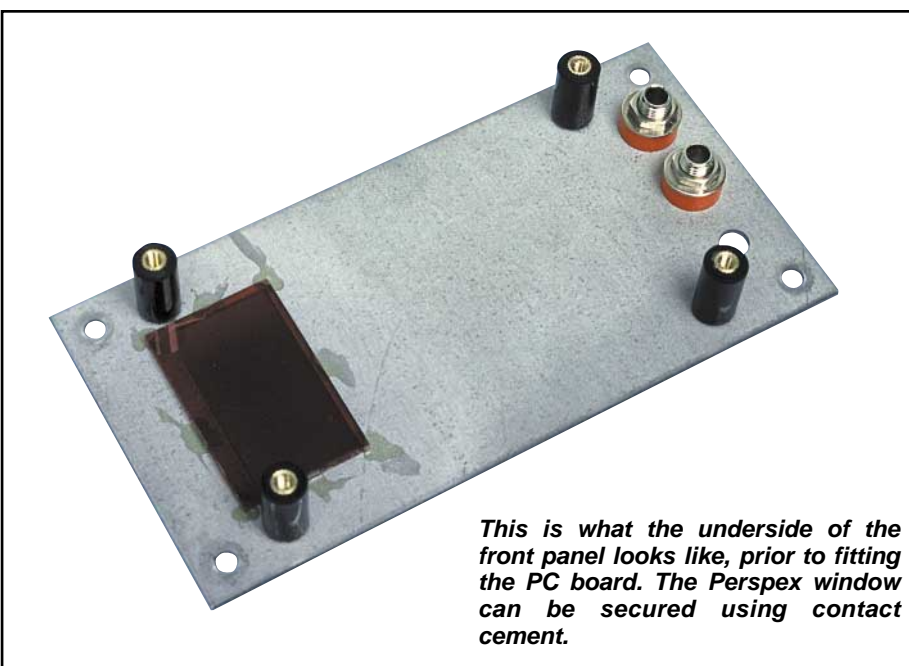

Fig.10b: Bend the battery terminals on the 4 x 'AAA' holder at 90 degrees and solder a short length of black hook-up wire to the negative (-ve) terminal. A piece of heatshrink tubing can be used to insulate the solder joint. Now bend the positive (+ve) terminal across and solder to the adjacent (-ve) terminal of the 2 x 'AAA' battery holder. Further details are shown above in Fig.10a.



than its maximum reading of 99Ω.

(2) Short the test leads together. The meter will display their resistance, typically 0.2-0.5Ω. Pushing the button again with the leads shorted should change the display to “.00” as the meter zeros out their resistance. However, it’s normal for this reading to change a bit, due to variations in contact resistance between the probes (remember that we’re measuring hundredths of one ohm!).

(3) Connect the supplied 68Ω 1% calibration resistor to the probes and carefully adjust VR2 until the meter reads “68”. That done, check that it reads the supplied 5.6Ω calibration resistor reasonably accurately.

Battery warning setup

Skip this bit if you disabled the automatic switch-off function by leaving one lead of R25 disconnected (see the “Optional Modifications” section).

This adjustment is easiest if you have access to a variable DC power supply. If not, you’ll need to temporarily build the little circuit shown in Fig.8. The adjustment procedure is as follows:

(1) With the meter off, unplug the test leads and turn VR1 fully anti-clockwise (as viewed from the copper side of the PC board).

(2) Adjust the supply voltage to 7.0V, then switch the meter on.

(3) Slowly turn VR1 clockwise until the “b” battery warning indication begins flashing on the righthand display.

(4) Turn the meter off, wind the power supply back up to 9V, then switch the meter back on and check that the battery warning triggers when you drop the supply back to 7.0V.

And that’s it! If everything went as planned, you can fully assemble your new ESR meter and start finding defective electrolytic capacitors. But first, read the panel entitled “Driving The ESR Meter Mk.2” – it not only contains useful hints but list the precautions that must be followed as well.

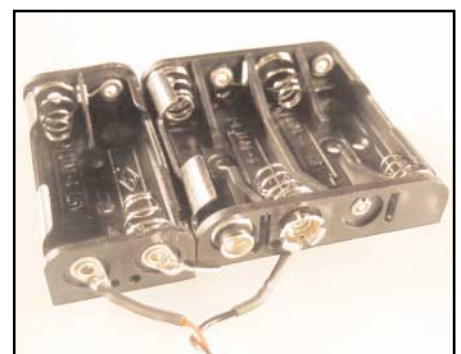

Check These Fault Codes If It Doesn't Work

What if it doesn't work? In that case, the Mk.2 ESR Meter's firmware allows the microcontroller to do some basic testing of the electronics, to help you narrow down a problem to one area of the board.

Before doing the self-test, it's very important to first set VR1 to the centre of its adjustment range and make sure that the meter's supply voltage is in the range of 8.5-9.5V.

Now switch the meter on by pressing and continuing to hold the button down, regardless of what the displays are showing. After five seconds, they'll go blank for a moment, then show a test result for two seconds. The meter will then switch off by itself after you release the button.

If everything is more or less OK, you'll see ".8.8" on the displays (this shows that all the display segments and decimal point LEDs are working). However, if the microcontroller has detected a major problem, it will flash a fault code consisting of an "F" on the lefthand display and a character from 0-9 or an "A" on the righthand one.

Experience has shown that by far the most common cause of ESR meter kits not working properly is defective soldering. When a fault code directs you to a particular part of the circuit, carefully check (using a bright light and magnifier) for solder whiskers, non-soldered joints and track damage such as lifted solder pads.

If you can't see anything abnormal, start checking for incorrect components and component placement errors such as transistors of the wrong type or with their leads in the wrong holes. If that doesn't show up anything, you might have received a defective component in the kit, though this is very rare.

OK, here's a list of what the fault codes indicate:

F0: Q11 is not discharging C10.

Check around Q11 (BC338), R21 (10k Ω), R22 (470k Ω) and pin 4 of IC2 (Z86E0412).

F1: C10 is charging too quickly. Check that R22 really is 470k Ω and that R19 & R20 are 10k Ω . Make sure C10 is 470nF (0.47 μ F, code "474"). Check also for soldering and component placement problems around transistors Q9 & Q10 (BC558).

F2: C10 is charging too slowly (or not at all). Check around Q9, Q10 (BC558), R22 (470k Ω), R19 & R20 (10k Ω) and C10 (470nF).

F3: Pulse amplifier output bias <440mV (ie, at collector of Q8). Check R13 (100k Ω) & R14 (220k Ω) for correct values and check that D6 isn't reversed. Check around Q7 (BC548), Q8 (BC558) and around pin 8 of IC2 plus associated components.

F4: Pulse amplifier output bias >1V. Carry out the same checks as for "F3" code. Check also that D5 isn't reversed.

F5: A test current source is permanently on. Check area around Q3, Q4 & Q5 (all BC328); R5, R7 & R9 (2.2k Ω); and pins 15, 16 & 17 of IC2.

F6: No output from pulse amplifier. This fault is usually due to the banana sockets being installed with +rt-circuiting them (see Fig.7). If that's not the problem, check around C7 (33nF), R12 (1k Ω), D3 & D4 (1N4002), C5 (100nF) and C6 (47 μ F bipolar).

F7: Q3 not sourcing current. Check around Q3 (BC328), R5* (2.2k Ω), R6 (10k Ω) and pin 15 of IC2.

F8: Q4 not sourcing current. Check around Q4 (BC328), R7* (2.2k Ω), R8 (1k Ω) and pin 16 of IC2.

F9: Q5 not sourcing current. Check around Q5 (BC328), R9* (2.2k Ω), R10 (100 Ω), IC2 pin 17.

FA: Q6 not switching on. Check around Q6 (BC338), R24 (10k Ω) and pin 1 of IC2.

Obviously, the microcontroller

can't perform detailed tests on every component, so it's possible that your meter is malfunctioning even though the self-testing hasn't shown up a problem.

For example, if the meter is behaving strangely, "freezing" up or giving absurd readings on some values of test resistors, the most likely cause is a mix-up in the values of R6 (10k Ω), R8 (1k Ω) and R10 (100 Ω).

On the other hand, if the meter produces readings but there's something wrong with the displayed characters, this is almost certainly due to one or more solder bridges between the pins of the large socket holding the displays, or around IC3.

If the meter doesn't stay switched on when you push the button, check around Q2 (BC338), R3 (15k Ω), R29 (2.7k Ω) and pin 2 of IC2. If it switches off when you short the test leads, R2 (4.7k Ω) may be the incorrect value or Q1 (BC328) may have a low current gain.

Finally, if you can't get the meter into the test mode, zero it or switch it off, check for solder "whiskers" and open circuits around pin 3 of IC2, R4 (47k Ω) and D2.

If none of the above has helped you to identify the problem, there's a page of fault-finding information on my website:

<http://members.ozemail.com.au/~bobpar/esrprob.htm>.

Do a Google search for "ESR meter faultfinding" if you can't find it. Also Ben Cook in Perth will get your meter working for a reasonable fee plus postage and handling. You can contact him at: **benok@iprimus.com.au**.

* The R5/7/9 area of the board seems to be a "magnet" for solder bridges and whiskers.

Optional Modifications

Heavy-duty protection

To provide greater protection against connection to charged electrolytics, some kit builders have connected an inverse-parallel pair of 1N5404 (or similar) high-power diodes between the test lead sockets. So if you're the kind who's likely to connect the meter to the 120 μ F input filter capacitor of a 240V-powered switching power supply without checking that it's been properly discharged, this modification is for you.

Reportedly, this protects the meter quite well, although it can result in the probe tips being blown off by large charged capacitors. The resulting surge current can also damage the charged capacitor and the power diodes themselves.

However, without the diodes, the resulting >600A current spike destroys the microcontroller (IC2) and damages C6.

Improving battery life

If you'd like to get even more battery life out of the meter (and are feeling a bit adventurous), you can replace IC1 (78L05) with an LP2950CZ-5.0 and replace R26 (10k Ω) with a 27k Ω resistor. That done, adjust trimpot VR1 so that the low battery warning triggers at 5.6V instead of the original 7.0V. (Thanks to G. Freeman, South Australia for this idea which was published in the August 1998 issue of "Electronics Australia" magazine).

Disabling automatic switch-off

If you'd like to power the meter from an external 9V DC supply and have it operating continuously, just disconnect one end of R25 (47k Ω). This disables the automatic switch-off function but note that the low battery warning will no longer work if you do this.

Of course, you can easily reconnect R25 if you change your mind in the future.

For more modifications, including a buzzer to help you discriminate between good and bad electrolytics without having to look at the meter, go to my ESR Meter Hints web page at

<http://members.ozemail.com.au/~bobpar/esrhints.htm>

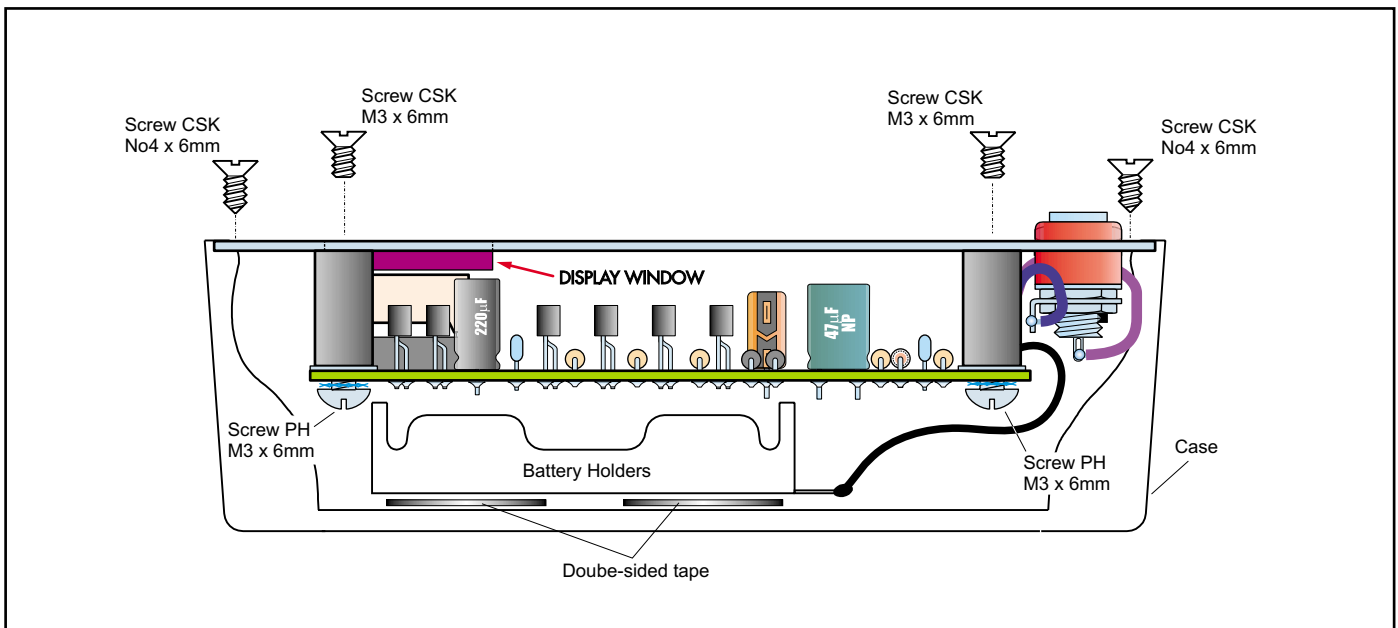
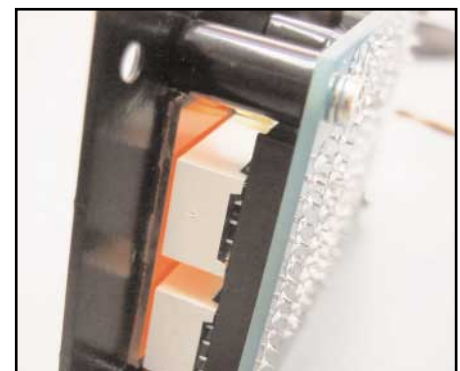
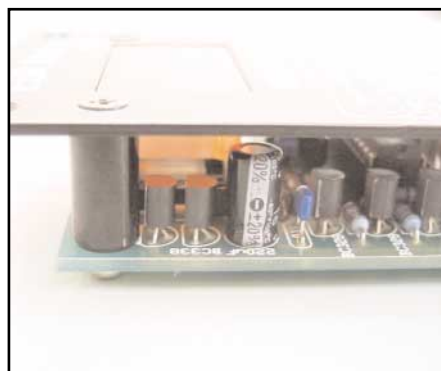
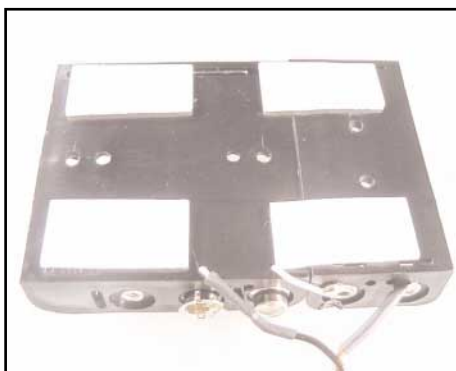

Fig.13: the battery holder is positioned on the bottom of the case and held in place by double sided tape.



Driving The ESR Meter Mk.2

The ESR Meter is extremely simple to operate but there are a few precautions to follow. First, here's its basic step-by-step operation:

- (1). Insert the plugs of the test leads into their sockets.
- (2). Press the button so the "-" symbol appears on the display.
- (3). Hold the test probes tightly together – the test lead resistance is displayed.
- (4). With the probes still together, press the button again to give a zeroed reading of ".00". You can repeat this at any time.
- (5). Measure the capacitor's ESR (it should be discharged first). A reading of "-" indicates a reading greater than 99Ω .
- (6). When you've finished measuring, press the button with the probes separated. The meter switches off when you release the button.
- (7). When the battery is getting low, "b" flashes once per second and the display dims to conserve the remaining battery capacity.

Precautions

(1). Beware charged capacitors: the very first thing to do is to make certain that the equipment you'll be using the ESR Meter on is disconnected from all power. Most electrolytic capacitors will be discharged by the circuitry around them within a few seconds of the power being switched off. However, be warned that filter capacitors in power supplies can remain dangerously charged, especially if there's a fault.

Before using the meter, make sure that all power supply capacitors are fully discharged. You can do this using well-insulated probes that include a series 100Ω 5W or similar power resistor. Don't just short the capacitor's terminals together; it can not only damage the capacitor but can also be dangerous.

Always allow several seconds to ensure a complete discharge. Apart from the risk of surprise and injury to you, large charged capacitors can seriously damage

the meter. If you think your ESR meter might be accidentally connected to electrolytics that are charged to high voltages, consider the extra protection idea described in the "Optional Modifications" panel.

(2). Watch out for interference: the meter can produce unsteady indications if its test leads pick up strong horizontal deflection signal voltages. To avoid this, be sure to keep it away from operating (CRT) TVs and monitors when making measurements.

(3). Use straight test leads: don't use self-retracting "curly" test leads with your meter. Their inductance can cause measurement errors. Also, be very careful not to confuse the ESR Meter's test leads with those from your multimeter! Keep them well separated.

What else can it do?

Since publication of the Mk.1 design in 1996, I've received a lot of feedback from imaginative ESR Meter users regarding other uses for it. The full list is on my website at

<http://members.ozemail.com.au/~bobpar/esrhints.htm> but here are some of the best ones:

(1). Resistance Measurement: as stated previously, this meter is really an AC ohmmeter with an equivalent test frequency of about 100kHz and capable of measuring non-inductive resistances from 0.01Ω to 99Ω . As such, it can be useful for locating short circuits on PC boards by showing the resistance of a copper track decreasing or increasing as you approach or move away from the short. For example, this is useful when trying to identify which one in a paralleled set of power

transistors is shorted (thanks Mike Diack).

You can also make your own very low-value resistors by measuring out a length of nichrome or similar resistance wire to give the required resistance. In addition, the ESR Meter can be used to check the contact resistance of switches, connectors and relays.

Just remember that any significant amount of inductance will cause measurement errors. You can't measure the DC resistance of a choke, transformer winding, video head or a roll of electrical cable, for example.

(2). Basic Signal Generator: the meter's test signal is a 500mV P-P (open circuit) burst of 8ms pulses at a 2kHz rate, repeated several times per second. As a result, it can be used as a signal source for basic checks on amplifiers, loudspeakers and other audio components (thanks Joe Lussy).

Maintenance

The meter's readings might become unsteady after a lot of use, due to oxidation or loosening of the test lead sockets. Heavily spray the test lead plugs with contact cleaner of the kind which evaporates completely (eg, CRC "CO" Contact Cleaner), then repeatedly insert and withdraw them from their sockets before it dries. If the test lead sockets have become loose, gently re-tighten them with long needle-nose pliers.

If the test probes have developed a resistive layer of oxidation, give them a wipe with a tissue soaked in tuner cleaner like CRC 2.26 or similar (thanks Joe Sopko).



Identifying Defective Electrolytics

If you're getting the idea that it's tricky to identify defective electrolytics, relax! Experience has shown that in almost every case, a capacitor's ESR needs to rise to at least 10 times its normal value to cause a circuit malfunction. Often, you'll find that it's risen to >30 times its normal value, or is so high that the meter just displays "-" (ie, >99Ω). So, with few exceptions, the electrolytic capacitor(s) causing a fault will be very obvious.

It's for this reason that the front panel figures don't need to be extremely accurate or complete. When you encounter an electrolytic whose value or voltage isn't on the chart, it's sufficient to assume that its ESR should be similar to that of a capacitor adjacent to it on the chart.

If you have any doubts, it's best to compare the meter's reading on a suspect capacitor with that of a new capacitor of the same value and voltage rating.

Note that the electrolytics which fail are often the ones that are close to heat-generating components such as power semiconductors and resistors, so check these first. It will save time if you mark each good capacitor with a felt-tipped pen as you go, so you know which ones still need to be checked.

Traps to avoid

All test equipment can produce

misleading indications under some conditions and the ESR Meter is no different. Because it is basically a high-frequency AC ohmmeter, it can't discriminate between a capacitor with a very low ESR and one which is short-circuit or very leaky.

In general, electrolytics with high ESR will cause faults such as switching power supplies losing regulation or failing to start, high-frequency noise in signal circuits, and distorted scanning waveforms in monitors and TV sets. In vintage equipment, they can cause hum and low frequency instability ("motorboating"), etc.

Conversely, leaky or shorted capacitors are likely to disturb the DC conditions of the circuit they are in, producing quite different kinds of faults. Tests with a multimeter should locate these. That said, in several decades of working on electronic gear, I've encountered less than a dozen shorted electrolytics but hundreds with high ESR!

If you find an electrolytic giving an ESR reading which seems too good (low) to be true, disconnect it from the circuit and measure its resistance with an ohmmeter – it might be short-circuit. In fact John Robertson from "John's Jukes" in Canada found that a cheap digital multimeter on a low ohms range can be connected in parallel with the ESR Meter without them dis-

turbing each other. Doing this allows the multimeter to show up those rare shorted electrolytics while you simultaneously check the ESR.

In some circuits such as in computer motherboards, switching power supplies and TV/monitor deflection stages, electrolytic capacitors are connected directly in parallel. In that case, a good capacitor can make the ESR of a (parallel) bad one appear to be much lower than it really is. You need to be aware of the circuit your suspect capacitor is in and disconnect it from circuit before making a measurement if necessary.

Beware Of Good ESR With Reduced Capacitance!

There's one more failure mode that you need to be aware of: when the ESR remains perfectly OK but the capacitance has dropped by a large amount. This is apparently quite rare but when it does happen, it can cause a lot of confusion.

If your ESR Meter shows that all the electrolytics seem OK but some strange fault is still present. try disconnecting and checking each capacitor in turn with capacitance meter. Alternatively, you could try temporarily connecting new capacitors in parallel with any suspect units (after turning the power off and discharging them).

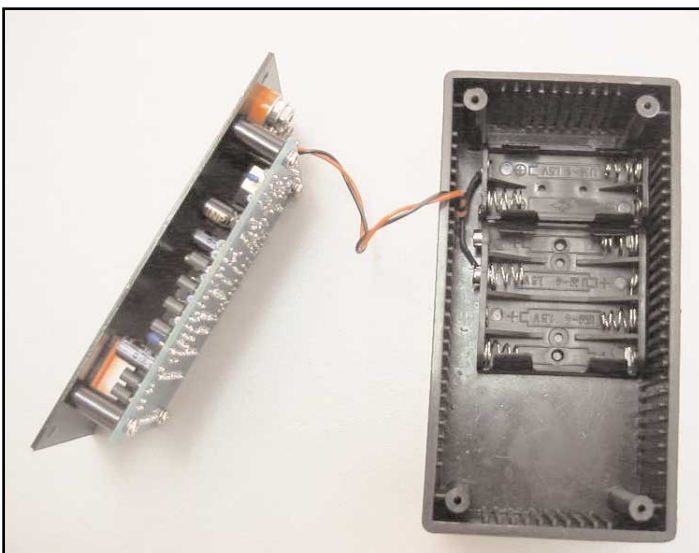

DICK SMITH
ELECTRONICS

A.B.N. 34 000 908 716

P.O. Box 500 Regents Park DC, NSW 2143

WEBSITE: www.dse.com.au

PH: (02) (Int 612) 9642 9100 Fax: (02) 9642 9111